

SECTION **SR**

SRS AIRBAG

A
B
C
D
E
F
G
SR
I
J
K
L
M
N
O
P

CONTENTS

PRECAUTION	3	BASIC INSPECTION	11
PRECAUTIONS	3	COLLISION DIAGNOSIS	11
Precaution for Supplemental Restraint System (SRS) "AIR BAG" and "SEAT BELT PRE-TENSIONER"	3	FOR FRONTAL COLLISION	11
Precautions for Removing Battery Terminal	3	FOR FRONTAL COLLISION : When SRS is activated in a collision	11
Occupant Classification System	3	FOR FRONTAL COLLISION : When SRS is not activated in a collision	12
Service	4	FOR SIDE AND ROLLOVER COLLISION	13
SYSTEM DESCRIPTION	5	FOR SIDE AND ROLLOVER COLLISION : When SRS is activated in a collision	13
COMPONENT PARTS	5	FOR SIDE AND ROLLOVER COLLISION : When SRS is not activated in a collision	14
AIR BAG MODULE	5	REMOVAL AND INSTALLATION	17
AIR BAG MODULE : Driver air bag module	5	DRIVER AIR BAG MODULE	17
AIR BAG MODULE : Passenger air bag module	5	Exploded View	17
AIR BAG MODULE : Side air bag module	6	Removal and Installation	17
AIR BAG MODULE : Curtain air bag module	6	SPIRAL CABLE	22
INFLATOR	7	Exploded View	22
INFLATOR : Driver air bag inflator	7	Removal and Installation	22
INFLATOR : Passenger air bag inflator	7	PASSENGER AIR BAG MODULE	25
INFLATOR : Side air bag inflator	8	Exploded View	25
INFLATOR : Curtain air bag inflator	8	Removal and Installation	25
MAIN COMPONENT PARTS AND FUNCTIONS	8	CURTAIN AIR BAG MODULE	28
MAIN COMPONENT PARTS AND FUNCTIONS : Spiral cable	8	Exploded View	28
MAIN COMPONENT PARTS AND FUNCTIONS : Crash zone sensor	8	Removal and Installation	28
MAIN COMPONENT PARTS AND FUNCTIONS : Satellite sensor	8	CRASH ZONE SENSOR	30
MAIN COMPONENT PARTS AND FUNCTIONS : Air bag diagnosis sensor unit	9	Exploded View	30
MAIN COMPONENT PARTS AND FUNCTIONS : Air bag warning lamp	10	Removal and Installation	30
MAIN COMPONENT PARTS AND FUNCTIONS : Occupant detection system control unit	10	SATELLITE SENSOR	32
MAIN COMPONENT PARTS AND FUNCTIONS : Occupant detection system sensor	10	Exploded View	32
		Removal and Installation	32
		SEAT BELT PRE-TENSIONER	35

Exploded View	35	Exploded View	37
Removal and Installation	35	Removal and Installation	37
LAP PRE-TENSIONER	36	OCCUPANT CLASSIFICATION SYSTEM	
Exploded View	36	CONTROL UNIT	39
Removal and Installation	36	Exploded View	39
DIAGNOSIS SENSOR UNIT	37	Removal and Installation	39

PRECAUTIONS

< PRECAUTION >

PRECAUTION

PRECAUTIONS

Precaution for Supplemental Restraint System (SRS) "AIR BAG" and "SEAT BELT PRE-TENSIONER"

INFOID:000000011285506

The Supplemental Restraint System such as "AIR BAG" and "SEAT BELT PRE-TENSIONER", used along with a front seat belt, helps to reduce the risk or severity of injury to the driver and front passenger for certain types of collision. This system includes seat belt switch inputs and dual stage front air bag modules. The SRS system uses the seat belt switches to determine the front air bag deployment, and may only deploy one front air bag, depending on the severity of a collision and whether the front occupants are belted or unbelted. Information necessary to service the system safely is included in the "SRS AIR BAG" and "SEAT BELT" of this Service Manual.

WARNING:

Always observe the following items for preventing accidental activation.

- To avoid rendering the SRS inoperative, which could increase the risk of personal injury or death in the event of a collision that would result in air bag inflation, all maintenance must be performed by an authorized NISSAN/INFINITI dealer.
- Improper maintenance, including incorrect removal and installation of the SRS, can lead to personal injury caused by unintentional activation of the system. For removal of Spiral Cable and Air Bag Module, see "SRS AIR BAG".
- Never use electrical test equipment on any circuit related to the SRS unless instructed to in this Service Manual. SRS wiring harnesses can be identified by yellow and/or orange harnesses or harness connectors.

PRECAUTIONS WHEN USING POWER TOOLS (AIR OR ELECTRIC) AND HAMMERS

WARNING:

Always observe the following items for preventing accidental activation.

- When working near the Air Bag Diagnosis Sensor Unit or other Air Bag System sensors with the ignition ON or engine running, never use air or electric power tools or strike near the sensor(s) with a hammer. Heavy vibration could activate the sensor(s) and deploy the air bag(s), possibly causing serious injury.
- When using air or electric power tools or hammers, always switch the ignition OFF, disconnect the battery, and wait at least 3 minutes before performing any service.

Precautions for Removing Battery Terminal

INFOID:000000011568288

- When removing the 12V battery terminal, turn OFF the ignition switch and wait at least 30 seconds.

NOTE:

ECU may be active for several tens of seconds after the ignition switch is turned OFF. If the battery terminal is removed before ECU stops, then a DTC detection error or ECU data corruption may occur.

- For vehicles with the 2-batteries, be sure to connect the main battery and the sub battery before turning ON the ignition switch.

NOTE:

If the ignition switch is turned ON with any one of the terminals of main battery and sub battery disconnected, then DTC may be detected.

- After installing the 12V battery, always check "Self Diagnosis Result" of all ECUs and erase DTC.

NOTE:

The removal of 12V battery may cause a DTC detection error.

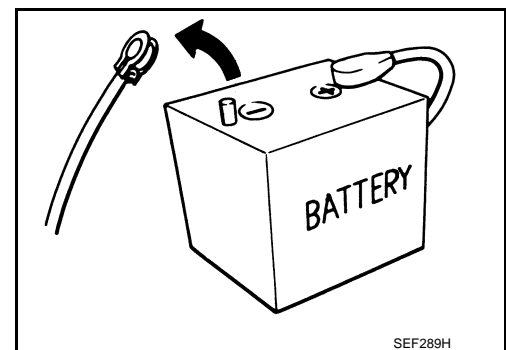

Occupant Classification System

INFOID:000000011285507

Replace occupant classification system control unit and passenger front seat cushion as an assembly. Refer to [SE-78, "Exploded View"](#).

PRECAUTIONS

< PRECAUTION >

Service

INFOID:000000011285508

- Never use electrical test equipment to check SRS circuits unless instructed to in this Service Manual.
- Before servicing the SRS, turn ignition switch OFF, disconnect battery negative terminal and wait at least 3 minutes.
For approximately 3 minutes after the cables are removed, it is still possible for the air bag and seat belt pretensioner to deploy. Therefore, never work on any SRS connectors or wires until at least 3 minutes have elapsed.
- Diagnosis sensor unit must always be installed with their arrow marks “←” pointing towards the front of the vehicle for proper operation. Also check diagnosis sensor unit for cracks, deformities or rust before installation and replace as required.
- The spiral cable must be aligned in the neutral position since its rotations are limited. Never turn steering wheel and column after removal of steering gear.
- Handle air bag module carefully. Always place driver and passenger air bag modules with the pad side facing upward and seat mounted side air bag module standing with the stud bolt side facing down.
- Conduct self-diagnosis to check entire SRS for proper functioning after replacing any components.
- After air bag inflates, the instrument panel assembly should be replaced if damaged.

COMPONENT PARTS

< SYSTEM DESCRIPTION >

SYSTEM DESCRIPTION

COMPONENT PARTS

AIR BAG MODULE

AIR BAG MODULE : Driver air bag module

INFOID:000000011285509

- Driver air bag module is built into steering wheel.
- Driver air bag module mainly consists of air bag ① and inflator ② which inflates air bag.

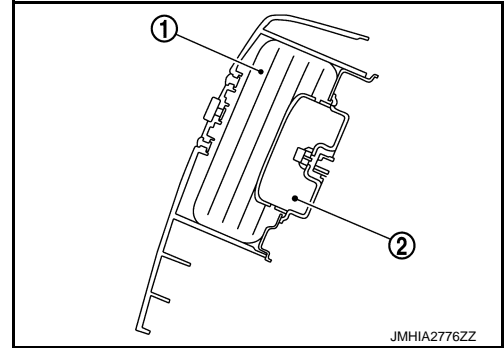

- Driver air bag inflates by breaking steering wheel center pad surface ①.

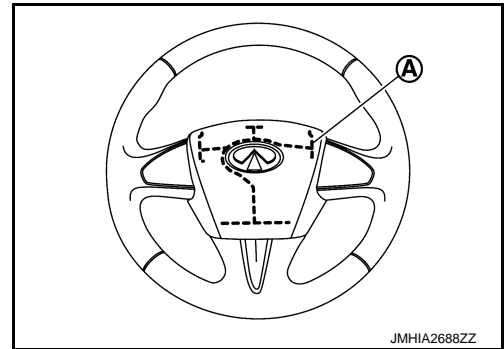

AIR BAG MODULE : Passenger air bag module

INFOID:000000011285510

- Passenger air bag module is built into instrument panel.
- Passenger air bag module mainly consists of air bag ① and inflator ② which inflates air bag.

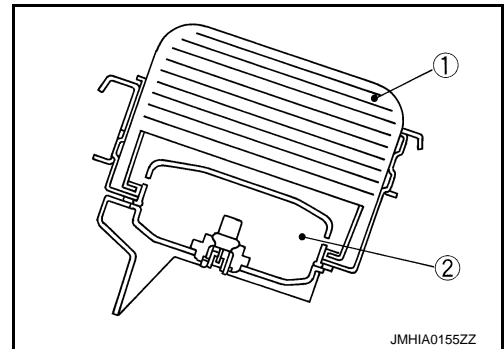

- Passenger air bag inflates by breaking instrument panel surface ①.

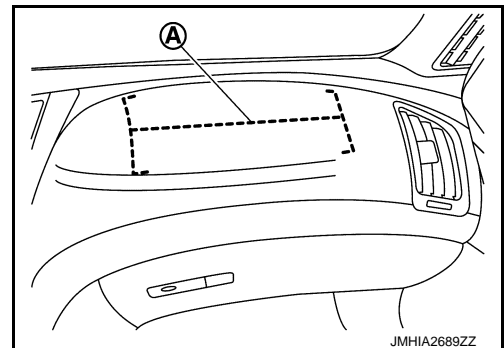

A
B
C
D
E
F
G
SR
I
J
K
L
M
N
O
P

COMPONENT PARTS

< SYSTEM DESCRIPTION >

AIR BAG MODULE : Side air bag module

INFOID:000000011285511

- Side air bag module is built into seatback side.
- Side air bag module mainly consists of air bag ① and inflator ② which inflates air bag.

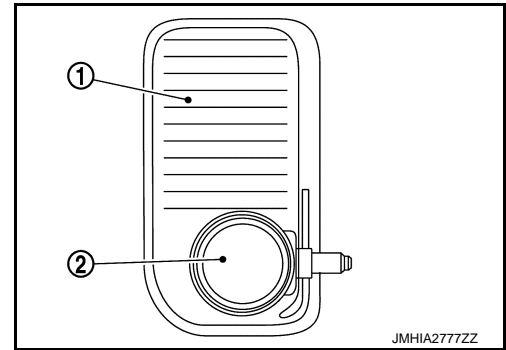

- Identification mark ① is installed to seatback side stitch indicating that side air bag is equipped.
- Side air bag inflates through seatback side stitch (A).

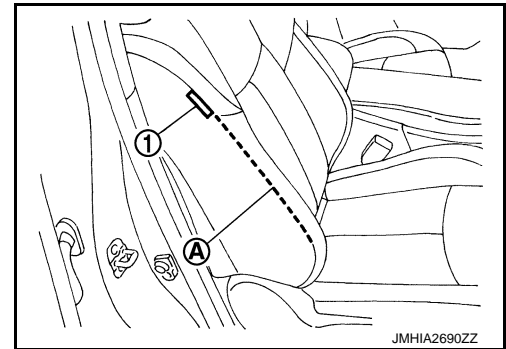

AIR BAG MODULE : Curtain air bag module

INFOID:000000011285512

- Curtain air bag module is built into roof side portion LH and RH.
- Curtain air bag module mainly consists of air bag ② and inflator ① which inflates air bag.

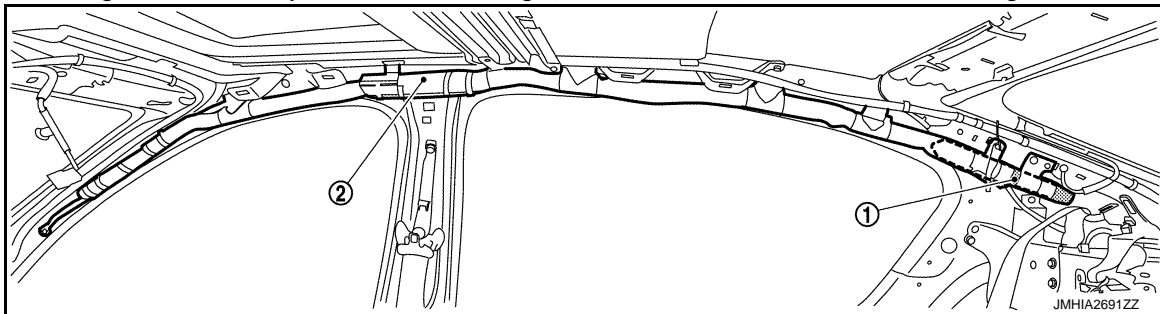

- Identification mark (A) is installed to center pillar upper garnish upper indicating that SRS curtain air bag is equipped.

COMPONENT PARTS

< SYSTEM DESCRIPTION >

- Curtain air bag inflates through a space ② between headliner and roof side portion.

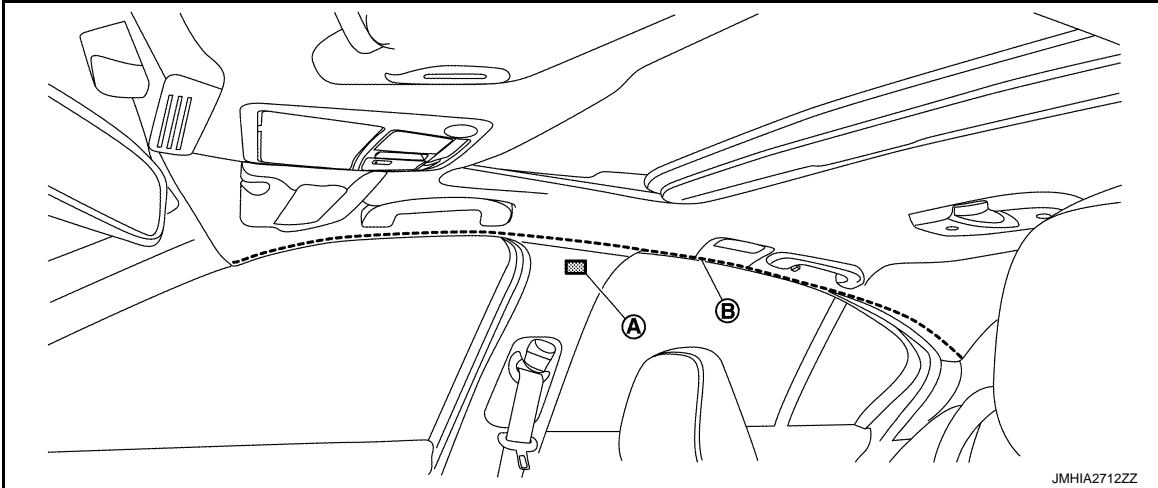

INFLATOR

INFLATOR : Driver air bag inflator

INFOID:000000011285513

- Driver air bag inflator ① mainly consists of electric ignition device (squib), igniting agent, gas generating agent, and filter. These items are stored in a container.
- In a frontal collision which exceeds the specified limit of the vehicle, electric ignition device (squib) ignites igniting agent. Gas generating agent burns due to heat from igniting agent. Generated gas (high temperature) inflates air bag through filter.

NOTE:

Filter removes and cools residues of gas generating agent.

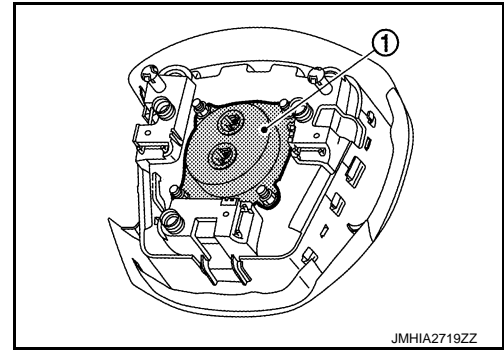

INFLATOR : Passenger air bag inflator

INFOID:000000011285514

- Passenger air bag inflator ① mainly consists of electric ignition device (squib), igniting agent, gas generating agent, and filter. These items are stored in a container.
- In a frontal collision which exceeds the specified limit of the vehicle, electric ignition device (squib) ignites igniting agent. Gas generating agent burns due to heat from igniting agent. Generated gas (high temperature) inflates air bag through filter.

NOTE:

Filter removes and cools residues of gas generating agent.

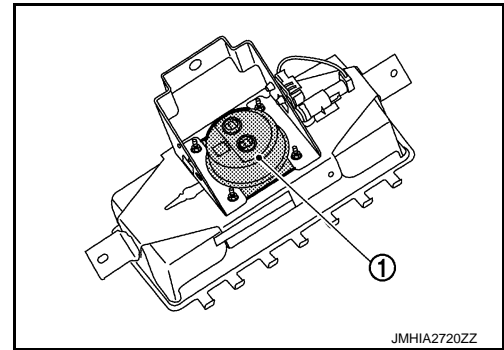

A
B
C
D
E
F
G
SR
I
J
K
L
M
N
O
P

COMPONENT PARTS

< SYSTEM DESCRIPTION >

INFLATOR : Side air bag inflator

INFOID:000000011285515

- Side air bag inflator ① mainly consists of electric ignition device (squib), heating agent, compressed gas, filter, and diffuser. These items are stored in a cylinder-type container.
- In a lateral collision which exceeds the specified limit of the vehicle, electric ignition device (squib) ignites igniting agent. Gas generating agent burns due to heat from igniting agent. Generated gas (high temperature) inflates air bag through filter.

NOTE:

Filter removes and cools residues of gas generating agent.

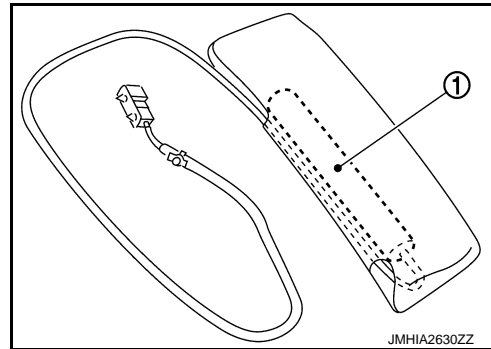

INFLATOR : Curtain air bag inflator

INFOID:000000011285516

- Curtain air bag inflator ① mainly consists of electric ignition device (squib), heating agent, compressed gas, and diffuser. These items are stored in a cylinder-type container.
- In a lateral collision which exceeds the specified limit of the vehicle, electric ignition device (squib) ignites igniting agent. Gas generating agent burns due to heat from igniting agent. Generated gas (high temperature) inflates air bag ② through filter.

NOTE:

Filter removes and cools residues of gas generating agent.

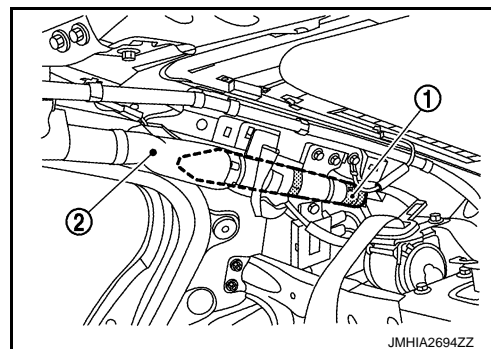

MAIN COMPONENT PARTS AND FUNCTIONS

MAIN COMPONENT PARTS AND FUNCTIONS : Spiral cable

INFOID:000000011285517

- Spiral cable electrically connects air bag diagnosis sensor unit and driver air bag module. Spiral cable mainly consists of the rotating portion (A) which performs the same movement as steering wheel, the fixed case (B) which is installed on steering wheel, and the cable which connects the rotating portion.
- Spiral cable is built into steering angle sensor which is installed to a space between combination switch and steering wheel.

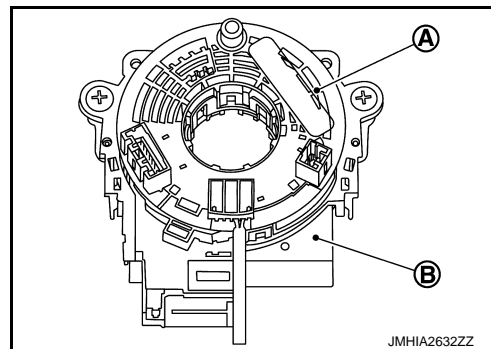

MAIN COMPONENT PARTS AND FUNCTIONS : Crash zone sensor

INFOID:000000011285518

- Crash zone sensor ① is installed to charge port lid hinge assembly. Crash zone sensor integrates frontal collision "G" sensor which detects frontal collision impact that exceeds the specified limit of the vehicle.
- In a frontal collision that exceeds the specified limit of the vehicle, crash zone sensor detects impact. If frontal collision safing sensor in air bag diagnosis sensor unit judges that impact is due to a collision, driver air bag, passenger air bag and seat belt pre-tensioner (front and rear) operate.

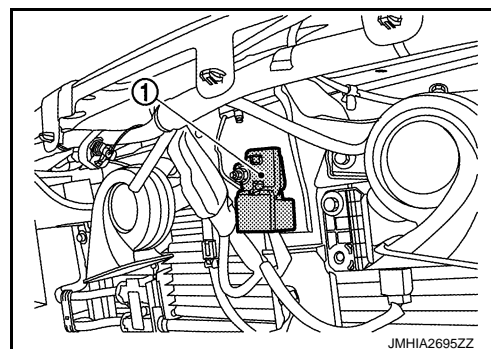

MAIN COMPONENT PARTS AND FUNCTIONS : Satellite sensor

INFOID:000000011285519

- Front door satellite sensor ① is installed to front door panel.

COMPONENT PARTS

< SYSTEM DESCRIPTION >

- B-pillar satellite sensor ② in installed to center pillar lower portion of front seat belt retractor front side.
- C-pillar satellite sensor ③ in installed to rear pillar lower.

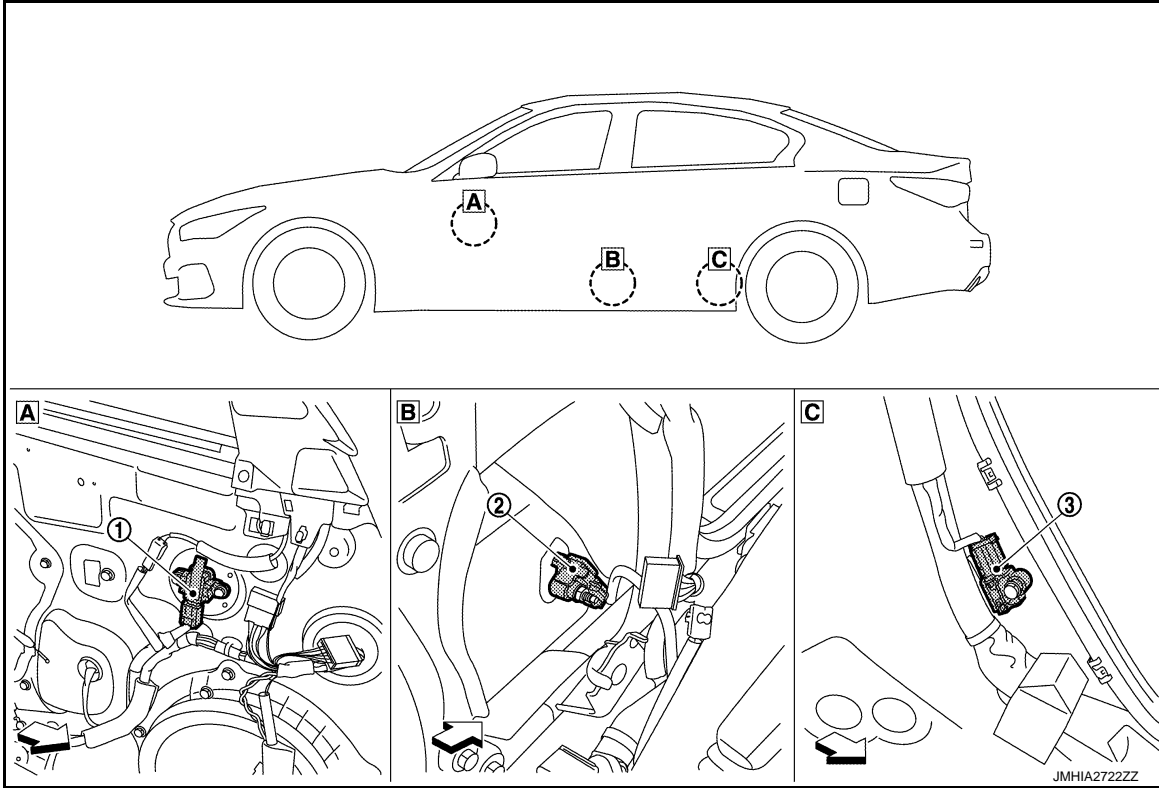

- ① Front door satellite sensor ② B-pillar satellite sensor ③ C-pillar satellite sensor

↔ : Vehicle front

- Satellite sensor integrates lateral collision “G” sensor which detects lateral collision impact that exceeds the specified limit of the vehicle. (Lateral collision “G” sensor adopts electronic sensor of which operating principles are the same as those of frontal collision “G” sensor in air bag diagnosis sensor unit.)
- In a lateral collision that exceeds the specified limit of the vehicle, satellite sensor detects impact. If lateral collision safing sensor in air bag diagnosis sensor unit judges that impact is due to a collision, side air bag, curtain air bag and front seat belt pre-tensioner operate.

MAIN COMPONENT PARTS AND FUNCTIONS : Air bag diagnosis sensor unit

INFOID:000000011285520

- Air bag diagnosis sensor unit is installed to front seat center portion (under center console). Air bag diagnosis sensor unit integrates control functions of driver air bag, passenger air bag, side air bag, curtain air bag, and seat belt pre-tensioner.

↔ : Vehicle front

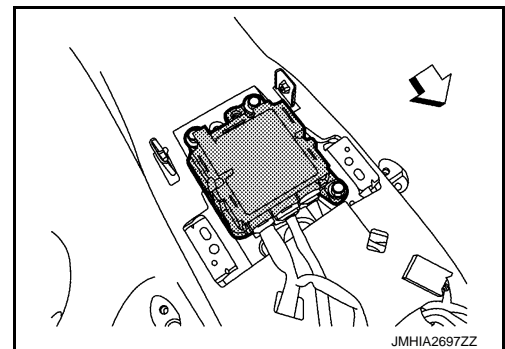

- Air bag diagnosis sensor unit integrates frontal collision “G” sensor, frontal collision safing sensor, and lateral collision safing sensor.
- Air bag diagnosis sensor unit has a function that judges impact due to frontal and lateral collisions exceeding the specified limit of the vehicle. Air bag diagnosis sensor unit also has an auxiliary power supply function that supplements battery power supply in the event battery is damaged in a collision.
- Air bag diagnosis sensor unit diagnoses electric system of entire air bag system. Self-diagnosis function is adopted, which indicates system malfunction by turning ON or blinking air bag warning lamp on combination meter when a malfunction is detected. Diagnosis using CONSULT is possible.

COMPONENT PARTS

< SYSTEM DESCRIPTION >

MAIN COMPONENT PARTS AND FUNCTIONS : Air bag warning lamp

INFOID:00000001128521

- Air bag warning lamp turns ON or blinks indicating a system malfunction when a malfunction is detected for electric system of SRS air bag system and seat belt pre-tensioner system. For turns ON/blinks pattern of air bag warning lamp, refer to [SRC-16, "On Board Diagnosis Function"](#).
- For operation check purposes, air bag warning lamp turns ON for 7 seconds after power switch is turned ON. During this period of time, air bag diagnosis sensor unit performs system diagnosis.
- Air bag warning lamp indicates self-diagnosis result according to the number of times it blinks. (in diagnosis mode)

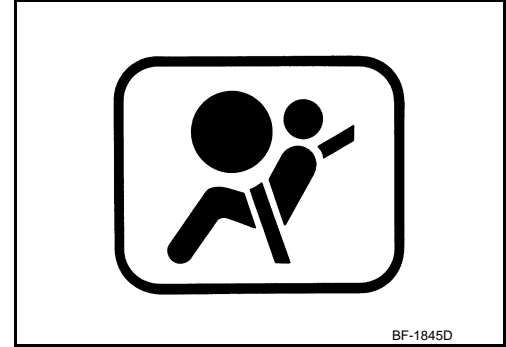

BF-1845D

NOTE:

SRS air bag and seat belt pre-tensioner do not operate for approximately 7 seconds (air bag warning lamp is turning ON) after power switch is turned ON.

MAIN COMPONENT PARTS AND FUNCTIONS : Occupant detection system control unit

INFOID:00000001128522

- Occupant detection system control unit installed in the passenger seat cushion frame.
- Occupant detection system control unit transmits the passenger seat status (occupied or empty) to air bag diagnosis sensor unit.

MAIN COMPONENT PARTS AND FUNCTIONS : Occupant detection system sensor

INFOID:00000001128523

- Occupant detection system sensor installed in the passenger seat cushion frame.
- Occupant detection system sensor transmits the passenger seat status (occupied or empty) to occupant detection system control unit.

COLLISION DIAGNOSIS

< BASIC INSPECTION >

BASIC INSPECTION

COLLISION DIAGNOSIS FOR FRONTAL COLLISION

FOR FRONTAL COLLISION : When SRS is activated in a collision

INFOID:000000001128524

CAUTION:

Due to varying models and option levels, not all parts listed in the chart below apply to all vehicles.

WORK PROCEDURE

1. Before performing any of the following steps, ensure that all vehicle body and structural repairs have been completed.
2. Replace the diagnosis sensor unit.
3. Remove the front air bag modules, crash zone sensor, bracket and seat belt pre-tensioner assemblies.
4. Check the SRS components using the table below:
Replace any SRS components showing visible signs of damage. (dents, cracks and deformation, etc.)
5. Install new front air bag modules, crash zone sensor assembly, bracket and seat belt pre-tensioner assemblies.
6. Perform self-diagnosis using CONSULT or air bag warning lamp. Refer to [SRC-16, "Description"](#) for details. Ensure entire SRS operates properly.
7. After the work is completed, check that no system malfunction is detected by air bag warning lamp in the user mode.

SRS INSPECTION (FOR FRONTAL COLLISION)

Part	Inspection
Driver air bag module	If the driver air bag has deployed: REPLACE Install with new fasteners.
Front passenger air bag module (if equipped)	If the front passenger air bag has deployed: REPLACE Install with new fasteners.
Crash zone sensor	If any of the front air bags or seat belt pre-tensioners* have been activated: REPLACE the crash zone sensor and bracket with new fasteners. *: Confirm seat belt pre-tensioner activation using CONSULT only.
Seat belt pre-tensioner assemblies (All applicable locations: buckle, retractor, lap outer)	If either the driver or passenger seat belt pre-tensioner* has been activated: REPLACE all seat belt pre-tensioner assemblies with new fasteners. *: Confirm seat belt pre-tensioner activation using CONSULT only.
Diagnosis sensor unit	If any of the SRS components have been activated: REPLACE the diagnosis sensor unit. Install with new fasteners.
Steering wheel	<ol style="list-style-type: none"> 1. Visually check steering wheel for deformities. 2. Check harness (built into steering wheel) and connectors for damage, and terminals for deformities. 3. Install driver air bag module into the steering wheel to check fit and alignment with the wheel. 4. Check steering wheel for excessive free play. 5. If no damage is found, reinstall. 6. If damaged – REPLACE.
Spiral cable	If the driver front air bag has deployed: REPLACE the spiral cable.
Occupant classification system (Passenger seat)	<ol style="list-style-type: none"> 1. Remove passenger seat assembly. 2. Check control unit case for dents, cracks or deformities. 3. Check connectors and pressure sensor tube for damage, and terminals for deformities. 4. Check seat frame and cushion pan for dents or deformities. 5. If no damage is found, reinstall seat with new fasteners. 6. If damaged – REPLACE seat cushion assembly with new fasteners.

COLLISION DIAGNOSIS

< BASIC INSPECTION >

Part	Inspection
Harness and connectors	<ol style="list-style-type: none"> 1. Check connectors for poor connection, damage, and terminals for deformities. 2. Check harness for binding, chafing, cuts, or deformities. 3. If no damage is found, reinstall the harness and connectors. 4. If damaged – REPLACE the damaged harness. Do not attempt to repair, splice or modify any SRS harness.
Instrument panel assembly	If the passenger air bag has deployed: REPLACE the instrument panel assembly. (integrated type)

FOR FRONTAL COLLISION : When SRS is not activated in a collision

INFOID:000000011285525

CAUTION:

Due to varying models and option levels, not all parts listed in the chart below apply to all vehicles.

WORK PROCEDURE

1. Before performing any of the following steps, ensure that all vehicle body and structural repairs have been completed.
2. Check the SRS components using the table below:
Replace any SRS components showing visible signs of damage. (dents, cracks and deformation, etc.)
3. Perform self-diagnosis using CONSULT or air bag warning lamp. Refer to [SRC-16. "Description"](#) for details. Ensure entire SRS operates properly.
4. After the work is completed, check that no system malfunction is detected by air bag warning lamp in the user mode.

SRS INSPECTION (FOR FRONTAL COLLISION)

Part	Inspection
Driver air bag module	<p>If the driver air bag has NOT been deployed:</p> <ol style="list-style-type: none"> 1. Remove driver air bag module. Check harness cover and connectors for damage, terminals for deformities, and harness for binding. 2. Install driver air bag module into the steering wheel to check fit and alignment with the wheel. 3. If no damage is found, reinstall with new fasteners. 4. If damaged – REPLACE. Install driver air bag module with new fasteners. <p style="color: red; margin-top: 5px;">CAUTION: Before disposing of such systems, deploy the systems.</p>
Front passenger air bag module (if equipped)	<p>If the front passenger air bag has NOT been deployed:</p> <ol style="list-style-type: none"> 1. Remove front passenger air bag module. Check harness cover and connectors for damage, terminals for deformities, and harness for binding. 2. Install front passenger air bag module into the instrument panel to check fit with the instrument panel. 3. If no damage is found, reinstall with new fasteners. 4. If damaged – REPLACE. Install front passenger air bag modules with new fasteners. <p style="color: red; margin-top: 5px;">CAUTION: Before disposing of such systems, deploy the systems.</p>
Crash zone sensor	<p>If the front air bags or seat belt pre-tensioners have NOT been activated:</p> <ol style="list-style-type: none"> 1. Remove the crash zone sensor. Check harness connectors for damage, terminals for deformities, and harness for binding. 2. Check for visible signs of damage (dents, cracks, deformation, etc.) of the crash zone sensor and bracket. 3. Install the crash zone sensor to check fit. 4. If no damage is found, reinstall with new fasteners. 5. If damaged – REPLACE the crash zone sensor and bracket with new fasteners.

COLLISION DIAGNOSIS

< BASIC INSPECTION >

Part	Inspection	
Seat belt pre-tensioner assemblies (All applicable locations: buckle, retractor, lap outer)	If the pre-tensioners have NOT been activated: <ol style="list-style-type: none"> 1. Remove seat belt pre-tensioners. Check harness cover and connectors for damage, terminals for deformities, and harness for binding. 2. Check belts for damage and anchors for loose mounting. 3. Check retractor for smooth operation. 4. Check seat belt adjuster for damage. 5. Check for deformities of the center pillar inner. 6. If no damage is found, reinstall seat belt pre-tensioner assembly. 7. If damaged – REPLACE. Install the seat belt pre-tensioners with new fasteners. <p>CAUTION: Before disposing of such systems, deploy the systems.</p>	A B C D
Diagnosis sensor unit	If none of the SRS components have been activated: <ol style="list-style-type: none"> 1. Check case for dents, cracks or deformities. 2. Check connectors for damage, and terminals for deformities. 3. If no damage is found, reinstall with new fasteners. 4. If damaged – REPLACE. Install diagnosis sensor unit with new fasteners. 	E
Steering wheel	<ol style="list-style-type: none"> 1. Visually check steering wheel for deformities. 2. Check harness (built into steering wheel) and connectors for damage, and terminals for deformities. 3. Install driver air bag module into the steering wheel to check fit and alignment with the wheel. 4. Check steering wheel for excessive free play. 5. If no damage is found, reinstall. 6. If damaged – REPLACE. 	F G
Spiral cable	If the driver front air bag has not deployed: <ol style="list-style-type: none"> 1. Visually check spiral cable and combination switch for damage. 2. Check connectors and protective tape for damage. 3. Check steering wheel for noise, binding or heavy operation. 4. If no damage is found, reinstall. 5. If damaged – REPLACE. 	SR I
Occupant classification system (Passenger seat)	<ol style="list-style-type: none"> 1. Remove passenger seat assembly. 2. Check control unit case for dents, cracks or deformities. 3. Check connectors and pressure sensor tube for damage, and terminals for deformities. 4. Check seat frame and cushion pan for dents or deformities. 5. If no damage is found, reinstall seat with new fasteners. 6. If damaged – REPLACE seat cushion assembly with new fasteners. 	J K
Harness and connectors	<ol style="list-style-type: none"> 1. Check connectors for poor connection, damage, and terminals for deformities. 2. Check harness for binding, chafing, cuts, or deformities. 3. If no damage is found, reinstall the harness and connectors. 4. If damaged – REPLACE the damaged harness. Do not attempt to repair, splice or modify any SRS harness. 	L
Instrument panel assembly	If the passenger air bag has NOT deployed: <ol style="list-style-type: none"> 1. Visually check instrument panel assembly for damage. 2. If no damage is found, reinstall the instrument panel assembly. 3. If damaged – REPLACE the instrument panel assembly. 	M

FOR SIDE AND ROLLOVER COLLISION

FOR SIDE AND ROLLOVER COLLISION : When SRS is activated in a collision

INFOID:0000000011285526

CAUTION:

Due to varying models and option levels, not all parts listed in the chart below apply to all vehicles.

WORK PROCEDURE

1. Before performing any of the following steps, ensure that all vehicle body and structural repairs have been completed.
2. Replace the following components:
 - Front seat back assembly (on the side on which side air bag is activated)
 - Satellite sensor LH/RH (on the side on which side air bag is activated)
 - Diagnosis sensor unit

COLLISION DIAGNOSIS

< BASIC INSPECTION >

- Seat belt pre-tensioner assemblies
3. Check the SRS components and the related parts using the following table.
Replace any SRS components and the related parts showing visible signs of damage. (dents, cracks, deformation, etc.)
 4. Perform self-diagnosis using CONSULT or air bag warning lamp. Refer to [SRC-16, "Description"](#) for details. Ensure entire SRS operates properly.
 5. After the work is completed, check that no system malfunction is detected by air bag warning lamp in the user mode.

SRS INSPECTION (FOR SIDE AND ROLLOVER COLLISION)

Part	Inspection
Side curtain air bag module LH	If the side curtain air bag LH has deployed: REPLACE the side curtain air bag module LH. Install with new fasteners.
Side curtain air bag module RH	If the side curtain air bag RH has deployed: REPLACE the side curtain air bag module RH. Install with new fasteners.
Front side air bag module LH	If the front side air bag LH has deployed: REPLACE front seatback assembly LH.
Front side air bag module RH	If the front side air bag RH has deployed: REPLACE front seatback assembly RH.
Side air bag (satellite) sensor (LH or RH)	If any of the SRS components have deployed: REPLACE the side air bag (satellite) sensor on the collision side with new fasteners.
Door (satellite) sensor (LH or RH)	If any of the SRS components have deployed: REPLACE the door (satellite) sensor on the collision side with new fasteners.
Diagnosis sensor unit	If any of the SRS components have deployed: REPLACE the diagnosis sensor unit with new fasteners.
Seat belt pre-tensioner assemblies (All applicable locations: buckle, retractor, lap outer)	If either the driver or passenger seat belt pre-tensioner* has been activated: REPLACE all seat belt pre-tensioner assemblies with new fasteners. *: Confirm seat belt pre-tensioner activation using CONSULT only.
Center inner pillar	1. Check the center inner pillar on the collision side for damage (dents, cracks, deformation, etc.). 2. If damaged – REPAIR the center inner pillar.
Trim/headlining	1. Check for visible signs of damage (dents, cracks, deformation, etc.) of the interior trim on the collision side. 2. If damaged – REPLACE the damaged trim parts.
Pop-up roll bar assemblies	If the pop-up roll bar has deployed: REPLACE pop-up roll bar assemblies and pop-up roll bar covers. Install with new fasteners.

FOR SIDE AND ROLLOVER COLLISION : When SRS is not activated in a collision

INFOID:000000011285527

CAUTION:

Due to varying models and option levels, not all parts listed in the chart below apply to all vehicles.

WORK PROCEDURE

1. Before performing any of the following steps, ensure that all vehicle body and structural repairs have been completed.
2. Check the SRS components and the related parts using the following table.
 - If the front seat back assembly is damaged, the front seat back assembly must be replaced.
 - If the door finisher assembly is damaged, the door finisher assembly and must be replaced.
3. Perform self-diagnosis using CONSULT or air bag warning lamp. Refer to [SRC-16, "Description"](#) for details. Ensure entire SRS operates properly.
4. After the work is completed, check that no system malfunction is detected by air bag warning lamp in the user mode.

SRS INSPECTION (FOR SIDE AND ROLLOVER COLLISION)

COLLISION DIAGNOSIS

< BASIC INSPECTION >

Part	Inspection	A
Side curtain air bag module LH	<p>If the side curtain air bag LH has NOT deployed:</p> <ol style="list-style-type: none"> 1. Check for visible signs of damage (dents, tears, deformation, etc.) of the center pillar on the collision side. 2. If damaged – Remove the side curtain air bag module LH. 3. Check for visible signs of damage (tears etc.) of the side curtain air bag module LH. 4. Check harness and connectors for damage, and terminals for deformities. 5. If no damage is found, reinstall the side curtain air bag module LH with new fasteners. 6. If damaged – REPLACE the side curtain air bag module LH with new fasteners. <p>CAUTION: Before disposing of such systems, deploy the systems.</p>	B C
Side curtain air bag module RH	<p>If the side curtain air bag RH has NOT deployed:</p> <ol style="list-style-type: none"> 1. Check for visible signs of damage (dents, tears, deformation, etc.) of the center pillar on the collision side. 2. If damaged – Remove the side curtain air bag module RH. 3. Check for visible signs of damage (tears etc.) of the side curtain air bag module RH. 4. Check harness and connectors for damage, and terminals for deformities. 5. If no damage is found, reinstall the side curtain air bag module RH with new fasteners. 6. If damaged – REPLACE the side curtain air bag module RH with new fasteners. <p>CAUTION: Before disposing of such systems, deploy the systems.</p>	D E F
Front side air bag module LH	<p>If the front side air bag LH has NOT deployed:</p> <ol style="list-style-type: none"> 1. Check for visible signs of damage (dents, tears, deformation, etc.) of the seat back on the collision side. 2. Check harness and connectors for damage, and terminals for deformities. 3. If damaged – REPLACE the front seatback assembly LH. <p>CAUTION: Before disposing of such systems, deploy the systems.</p>	G SR
Front side air bag module RH	<p>If the front side air bag RH has NOT deployed:</p> <ol style="list-style-type: none"> 1. Check for visible signs of damage (dents, tears, deformation, etc.) of the seat back on the collision side. 2. Check harness and connectors for damage, and terminals for deformities. 3. If damaged – REPLACE the front seatback assembly RH. <p>CAUTION: Before disposing of such systems, deploy the systems.</p>	I J
Side air bag (satellite) sensor (LH or RH)	<p>If none of the SRS components have been activated:</p> <ol style="list-style-type: none"> 1. Remove the side air bag (satellite) sensor (LH or RH) on the collision side. Check harness connectors for damage, terminals for deformities, and harness for binding. 2. Check for visible signs of damage (dents, cracks, deformation, etc.) of the side air bag (satellite) sensor (LH or RH). 3. Install the side air bag (satellite) sensor (LH or RH) to check fit. 4. If no damage is found, reinstall the side air bag (satellite) sensor (LH or RH) with new fasteners. 5. If damaged – REPLACE the side air bag (satellite) sensor (LH or RH) with new fasteners. 	K L
Door (satellite) sensor (LH or RH)	<p>If none of the SRS components have been activated:</p> <ol style="list-style-type: none"> 1. Remove the door (satellite) sensor (LH or RH) on the collision side. Check harness connectors for damage, terminals for deformities, and harness for binding. 2. Check for visible signs of damage (dents, cracks, deformation, etc.) of the door (satellite) sensor (LH or RH). 3. Install the door (satellite) sensor (LH or RH) to check fit. 4. If no damage is found, reinstall the door (satellite) sensor (LH or RH) with new fasteners. 5. If damaged – REPLACE the door (satellite) sensor (LH or RH) with new fasteners. 	M N
Diagnosis sensor unit	<p>If none of the SRS components have been activated:</p> <ol style="list-style-type: none"> 1. Check case and bracket for dents, cracks or deformities. 2. Check connectors for damage, and terminals for deformities. 3. If no damage is found, reinstall the diagnosis sensor unit with new fasteners. 4. If damaged – REPLACE the diagnosis sensor unit with new fasteners. 	O P

COLLISION DIAGNOSIS

< BASIC INSPECTION >

Part	Inspection
Seat belt pre-tensioner assemblies (All applicable locations: buckle, retractor, lap outer)	If the pre-tensioners have NOT been activated: <ol style="list-style-type: none"> 1. Remove seat belt pre-tensioners. Check harness cover and connectors for damage, terminals for deformities, and harness for binding. 2. Check belts for damage and anchors for loose mounting. 3. Check retractor for smooth operation. 4. Check seat belt adjuster for damage. 5. Check for deformities of the center pillar inner. 6. If no damage is found, reinstall seat belt pre-tensioner assembly. 7. If damaged – REPLACE. Install the seat belt pre-tensioners with new fasteners. <p>CAUTION: Before disposing of such systems, deploy the systems.</p>
Seat (with side air bag)	If the front LH or front RH side air bag modules have NOT deployed: <ol style="list-style-type: none"> 1. Visually check the seat on the collision side. 2. Remove the seat on the collision side and check the following for damage and deformities. <ul style="list-style-type: none"> - Harness, connectors and terminals - Frame and recliner (for front and rear seat), and also adjuster and slides (for front seat) 3. If no damage is found, reinstall the seat. 4. If damaged – REPLACE the damaged seat parts using new fasteners. If the front seat back is damaged, the front seat back assembly must be replaced.
Center inner pillar	<ol style="list-style-type: none"> 1. Check the center inner pillar on the collision side for damage (dents, cracks, deformation, etc.). 2. If damaged – REPAIR the center inner pillar.
Trim/headlining	<ol style="list-style-type: none"> 1. Check for visible signs of damage (dents, cracks, deformation, etc.) of the interior trim on the collision side. 2. If damaged – REPLACE the damaged trim parts.
Pop-up roll bar	If the pop-up roll bar has NOT deployed: <ol style="list-style-type: none"> 1. Check for visible signs of damage (dents, tears, deformation, etc.) of the pop-up roll bar. 2. If damaged – REPLACE the pop-up roll bar with new fasteners. 3. Check harness and connectors for damage, and terminals for deformities. 4. If no damage is found, reinstall the pop-up roll bar with new fasteners. 5. Check for visible signs of damage (dents, cracks, deformation, etc.) of the seatback support brace assembly. 6. If damaged – REPAIR the seatback support brace assembly.

DRIVER AIR BAG MODULE

< REMOVAL AND INSTALLATION >

REMOVAL AND INSTALLATION

DRIVER AIR BAG MODULE

Exploded View

INFOID:000000011285528

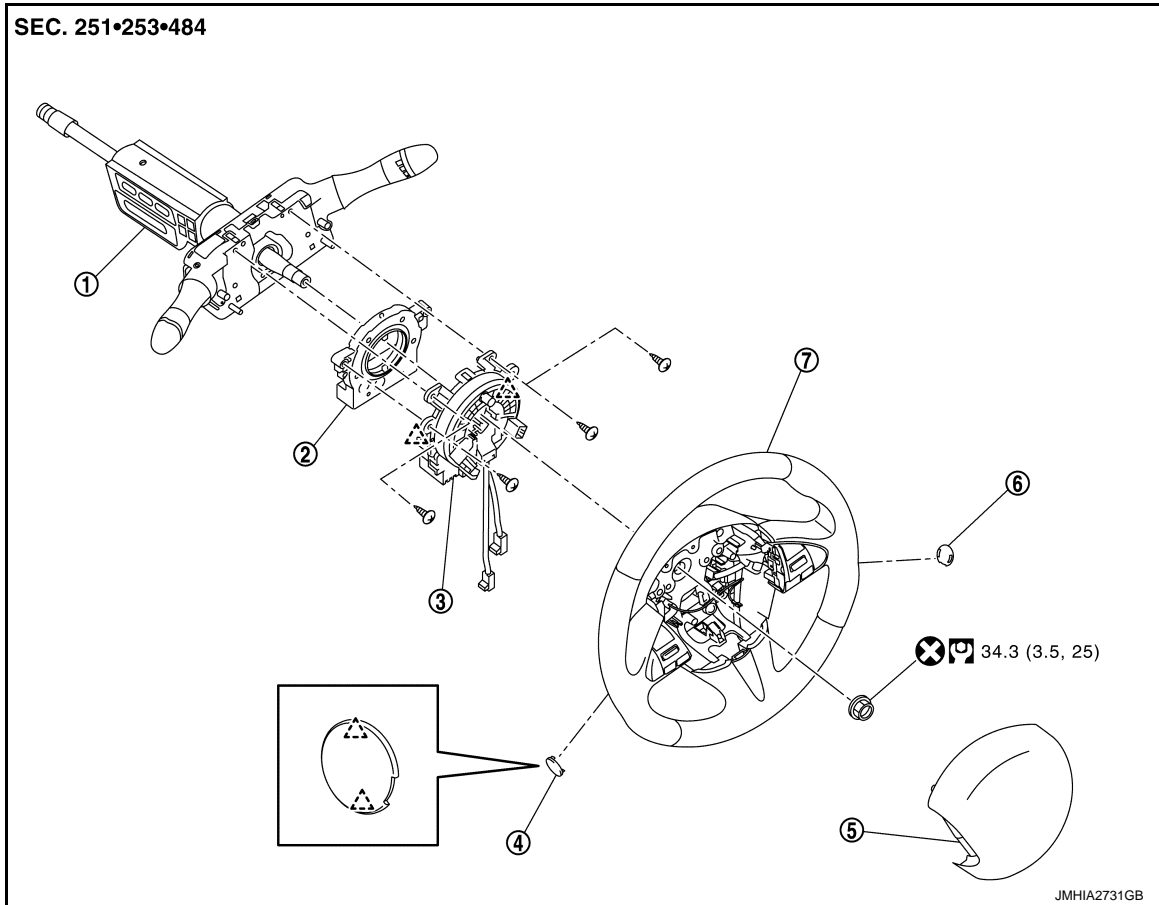

- | | | |
|----------------------------|-------------------------|----------------|
| ① Steering column assembly | ② Driver angle sensor | ③ Spiral cable |
| ④ Side lid LH | ⑤ Driver air bag module | ⑥ Side lid RH |
| ⑦ Steering wheel | | |

△ : Pawl

⊗ : Always replace after every disassembly.

Ⓜ : N·m (kg·m, ft·lb)

Removal and Installation

INFOID:000000011285529

WARNING:

Always observe the following items for preventing accidental activation.

- Before servicing, turn ignition switch OFF, disconnect battery negative terminal and wait for 3 minutes or more (discharges electricity held in the additional power supply circuit of the air bag diagnosis sensor unit).
- Always work from the side of air bag module. Never work in front of it.

REMOVAL

DRIVER AIR BAG MODULE

< REMOVAL AND INSTALLATION >

1. From the holes on the left and right of the steering wheel, check the position of the torsion springs that secure the driver air bag module.

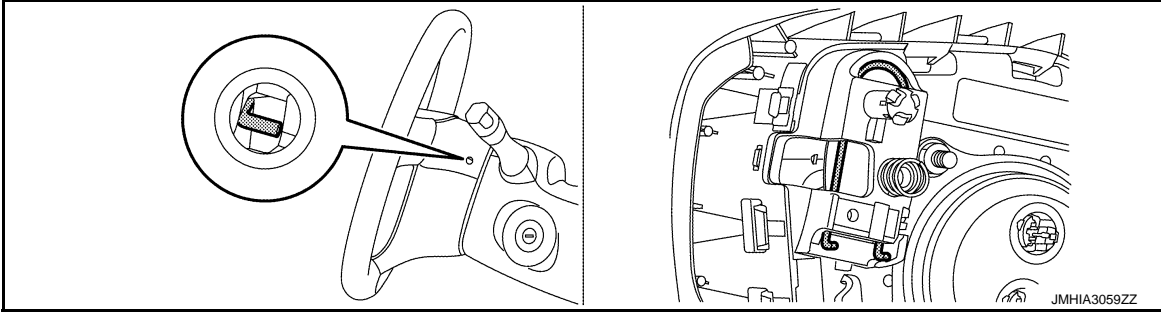

2. Insert a flat-bladed screwdriver (A) into a hole on the left side or the right side of the steering wheel, and place the end of the flat-bladed screwdriver (A) on the torsion spring ①.

CAUTION:

For preventing damage, wrap protective tape around the end of the flat-bladed screwdriver.

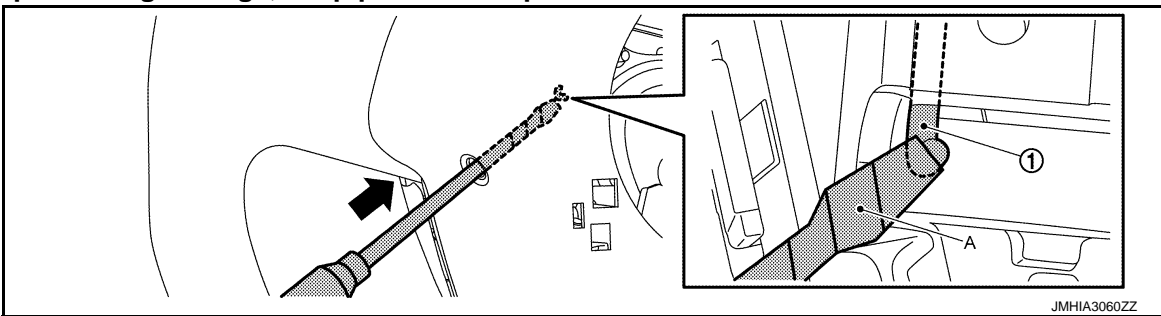

3. Press and hold the driver air bag module on the side where the flat-bladed screwdriver is inserted.

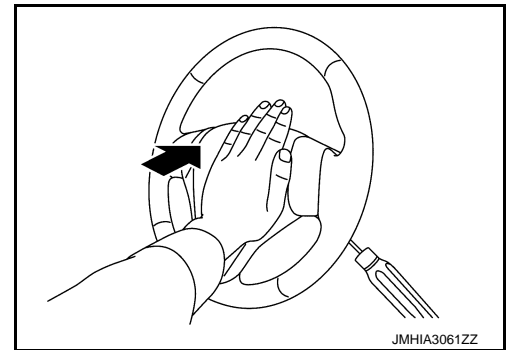

4. Press and disengage the torsion spring ① by using the inserted flat-bladed screwdriver (A).

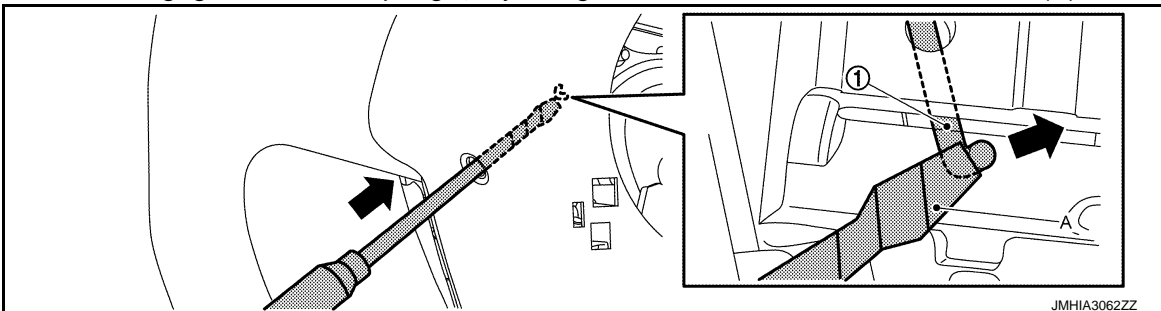

DRIVER AIR BAG MODULE

< REMOVAL AND INSTALLATION >

5. Pull the driver air bag module, previously pressed and held, and then pull out the flat-bladed screwdriver from the steering wheel.

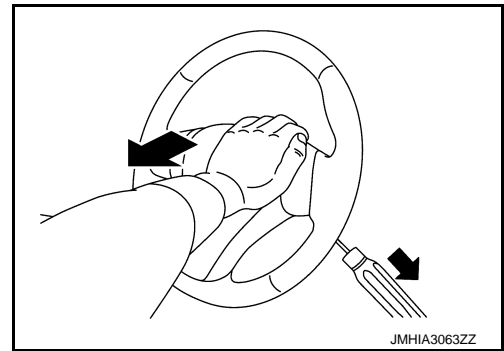

6. Remove the remaining torsion springs in numerical order from 1 to 5.
7. Lift up driver air bag module lower side from vehicle front to upwards while pulling driver air bag module upper side according to the numerical order 1→2 as shown in the figure, and then pull out driver air bag module.

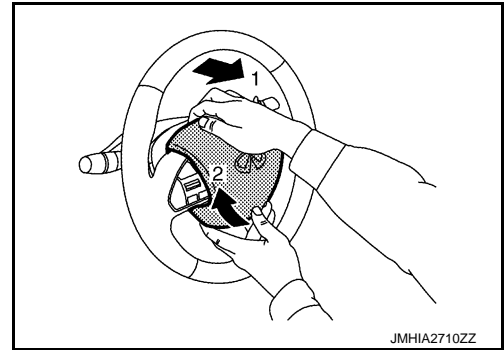

8. Disconnect driver air bag module harness connectors (B) and horn switch harness terminal (A).

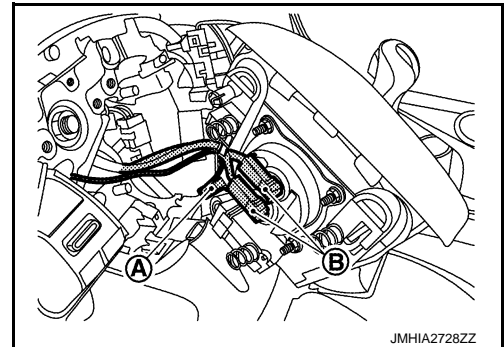

CAUTION:

- For installing/removing the driver air bag module harness connector, insert a thin screwdriver wrapped in tape into notch, lift lock and remove the connector.
- Install the connector with lock raised, and push lock into the connector.
- After installing the connector, check that the lock is pushed securely into it.

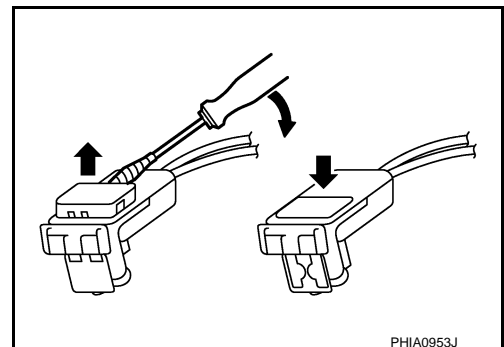

9. Remove driver air bag module.

CAUTION:

DRIVER AIR BAG MODULE

< REMOVAL AND INSTALLATION >

- To prevent accidental explosion, always place the driver air bag module with deploying direction facing upward.

↖ : Deploying direction

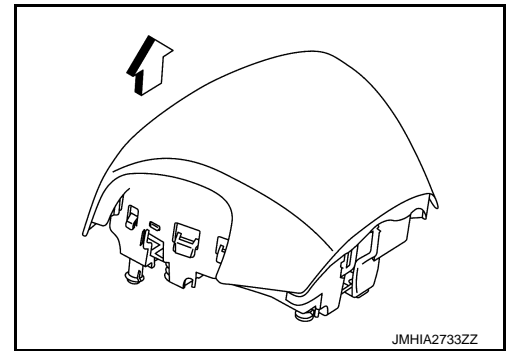

- To prevent damage to the driver air bag module, never impact it.
- Replace the driver air bag module if it is dropped or sustains an impact.



- To prevent accidental explosion, never insert any foreign objects (screwdriver, etc.) into the driver air bag module.
- To prevent accidental explosion, never disassemble the driver air bag module.
- To prevent accidental explosion, never expose the driver air bag module to temperatures of more than 90 °C (194 °F).
- To prevent damage to the parts, never allow oil, grease, detergent, or water to come in contact with the driver air bag module.

INSTALLATION

Note the following items, and then install in the reverse order of removal.

CAUTION:

- Fix the driver air bag module harness to the harness fixing hook (A).

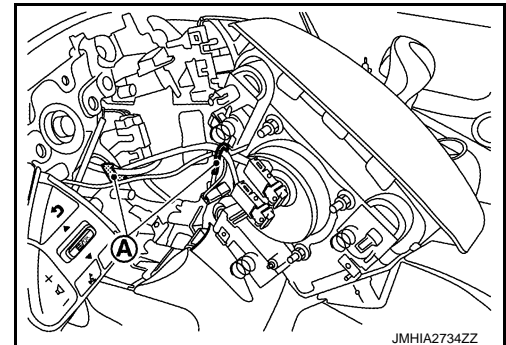

- Press driver air bag module upper (A) until it snaps into place with a clicking sound.

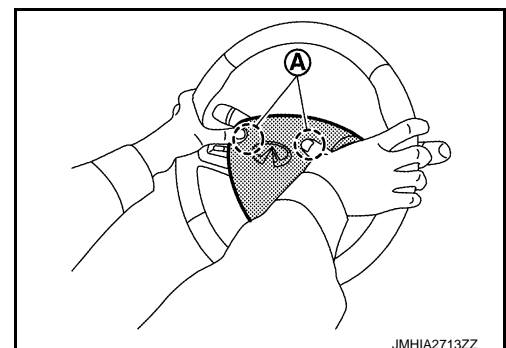

DRIVER AIR BAG MODULE

< REMOVAL AND INSTALLATION >

- Press driver air bag module lower (A) until it snaps into place with a clicking sound.

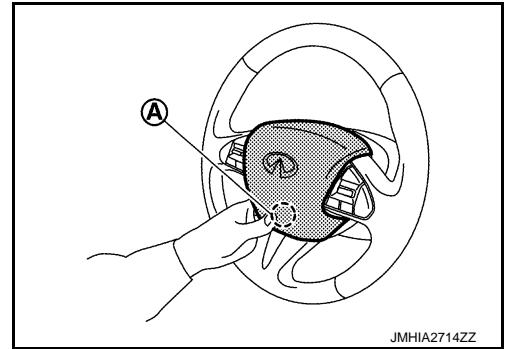

- Check that horn does not sound when driver air bag module is not pressed.
- Never damage the harness while installing.
- After installation is complete, perform self-diagnosis using CONSULT or air bag warning lamp, if the system is normal and "PAST" of "Self Diagnostic Result" is indicated, always perform "ERASE" of "Self Diagnostic Result" using CONSULT. Refer to [SRC-38. "Work Flow"](#).
- After the work is completed, check that no system malfunction is detected by air bag warning lamp in the user mode.

A
B
C
D
E
F
G
SR
I
J
K
L
M
N
O
P

SPIRAL CABLE

< REMOVAL AND INSTALLATION >

SPIRAL CABLE

Exploded View

INFOID:000000011285530

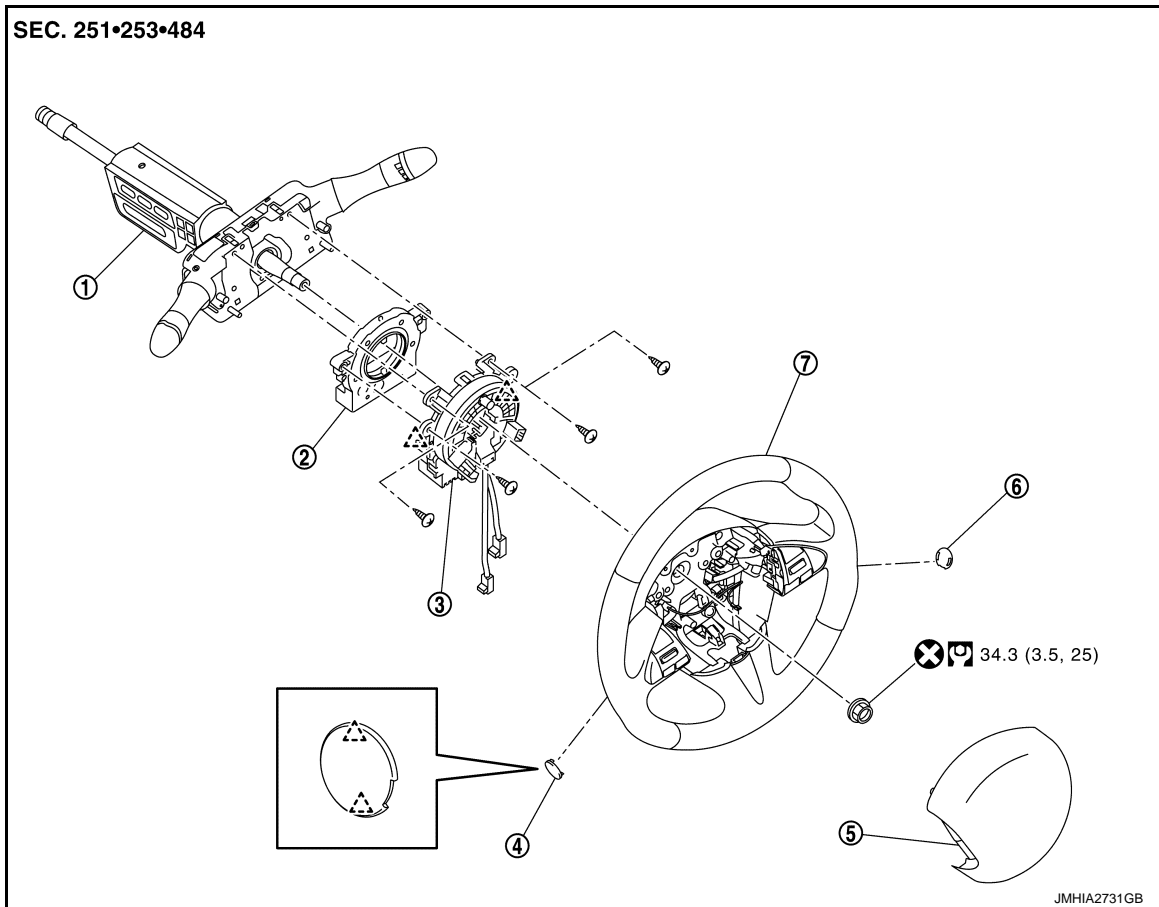

- | | | |
|----------------------------|-------------------------|----------------|
| ① Steering column assembly | ② Driver angle sensor | ③ Spiral cable |
| ④ Side lid LH | ⑤ Driver air bag module | ⑥ Side lid RH |
| ⑦ Steering wheel | | |

△ : Pawl

⊗ : Always replace after every disassembly.

⊕ : N·m (kg-m, ft-lb)

Removal and Installation

INFOID:000000011285531

WARNING:

Always observe the following items for preventing accidental activation.

- Before servicing, turn ignition switch OFF, disconnect battery negative terminal and wait for 3 minutes or more (discharges electricity held in the additional power supply circuit of the air bag diagnosis sensor unit).

REMOVAL

1. Remove driver air bag module. Refer to [SR-17, "Removal and Installation"](#).
2. Remove steering wheel. Refer to [ST-31, "Removal and Installation"](#) (VEHICLE SPEED SENSITIVE P/S models) or [ST-91, "Removal and Installation"](#) (DIRECT ADAPTIVE STEERING models).
3. Remove steering column upper cover and steering column lower cover. Refer to [IP-13, "Removal and Installation"](#).

SPIRAL CABLE

< REMOVAL AND INSTALLATION >

- Remove paddle shifter (shift-up switch) and paddle shifter (shift-down switch). Refer to [TM-214. "Removal and Installation"](#). (with paddle shifter models)
- Disconnect spiral cable body side harness connectors (A) and (B).
NOTE:
Disconnect the spiral cable body side harness connector (A) after removing the spiral cable body side harness connector (B).
- Disconnect steering angle sensor harness connector (C).

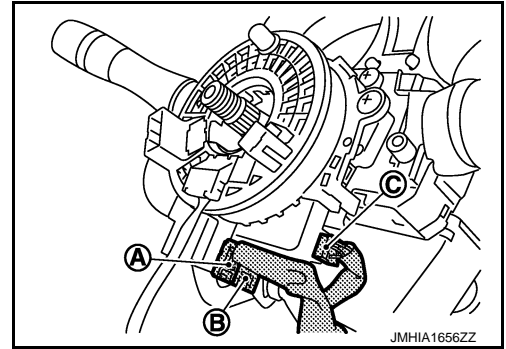

- Remove spiral cable fixing screws.
- Remove spiral cable fixing pawls with remover tool (A), then remove the spiral cable.

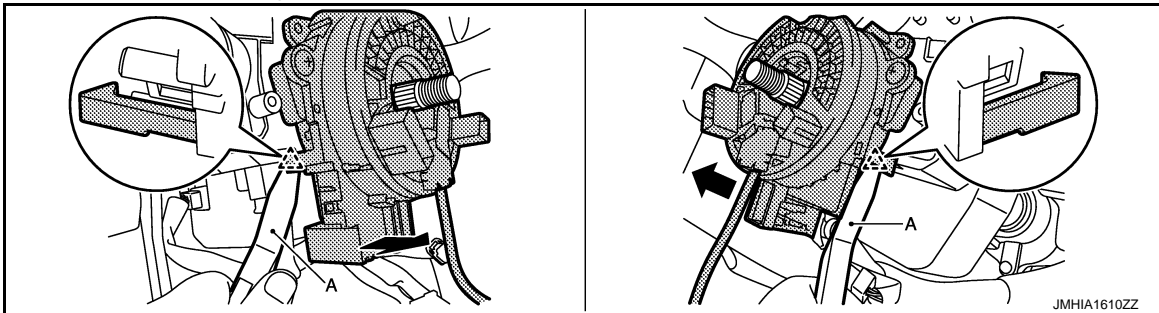

 : Pawl

CAUTION:

Remove pawls slowly so that they are not damaged.

- Remove the steering angle sensor.

CAUTION:

- To prevent damage to the spiral cable, never impact it.
- Replace the spiral cable if it is dropped or sustains an impact.



- To prevent damage to the parts, never disassemble the spiral cable.
- To prevent damage to the parts, never apply lubricant to the spiral cable.
- To prevent damage to the parts, never allow oil, grease, detergent, or water to come in contact with the spiral cable.

INSTALLATION

Note the following items, and then install in the reverse order of removal.

CAUTION:

SPIRAL CABLE

< REMOVAL AND INSTALLATION >

- The spiral cable may snap during steering operation if the cable is installed in an improper position.
The neutral position is set as per the following.
- Carefully turn the spiral cable clockwise to the end position. Then turn it counterclockwise (about 2 and a half turns) and stop turning at the mark (B) on which clear window (C) appears white
- The service part is installed in the neutral position by the stopper and can be set without adjusting after the stopper is removed.
- Never over turn the spiral cable or go beyond the number of turns required. (This causes the cable to snap)
- Adjust the spiral cable locating pin (A) to the steering wheel locating pin hole (D).

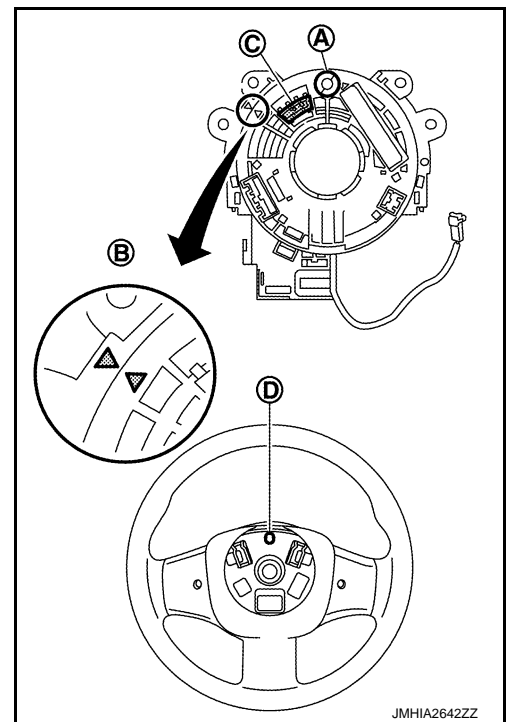

- Fix the driver air bag module harness to the harness fixing hook (A).

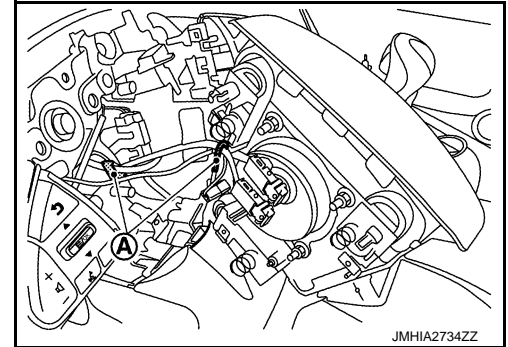

- After installation is complete, perform self-diagnosis using CONSULT or air bag warning lamp, if the system is normal and "PAST" of "Self Diagnostic Result" is indicated, always perform "ERASE" of "Self Diagnostic Result" using CONSULT. Refer to [SRC-38. "Work Flow"](#).
- After the work is completed, check that no system malfunction is detected by air bag warning lamp in the user mode.

PASSENGER AIR BAG MODULE

< REMOVAL AND INSTALLATION >

PASSENGER AIR BAG MODULE

Exploded View

INFOID:000000011285532

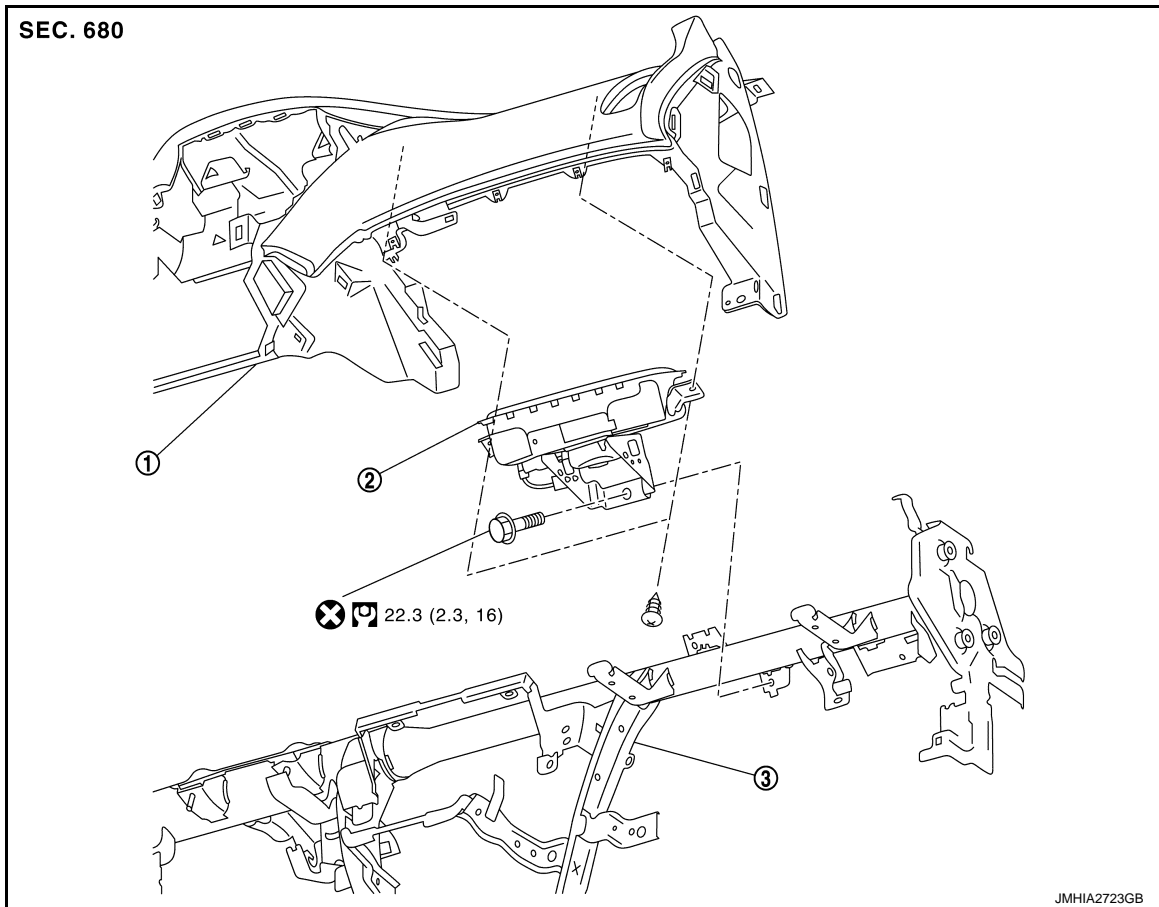

- ① Instrument panel assembly ② Passenger air bag module ③ Steering member assembly

⊗ : Always replace after every disassembly.

Ⓜ : N·m (kg-m, ft-lb)

Removal and Installation

INFOID:000000011285533

WARNING:

Always observe the following items for preventing accidental activation.

- Before servicing, push power switch OFF, disconnect battery negative terminal and wait for 3 minutes or more (discharges electricity held in the additional power supply circuit of the air bag diagnosis sensor unit).
- Always work from the side of air bag module. Never work in front of it.

REMOVAL

1. Remove glove box assembly. Refer to [IP-13. "Removal and Installation"](#).

PASSENGER AIR BAG MODULE

< REMOVAL AND INSTALLATION >

2. Disconnect harness connectors (B) and harness clip (D), and then remove fixing screws (A) and mounting bolt (C).

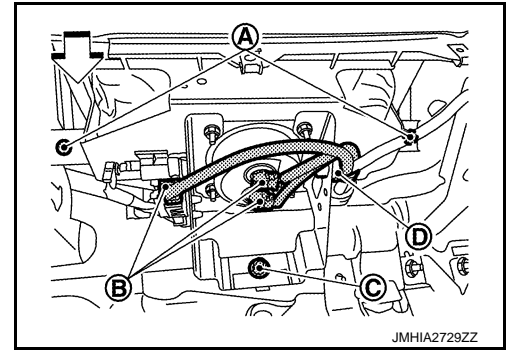

CAUTION:

- For installing/removing the driver air bag module harness connector, insert a thin screwdriver wrapped in tape into notch, lift lock and remove the connector.
- Install the connector with lock raised, and push lock into the connector.
- After installing the connector, check that the lock is pushed securely into it.

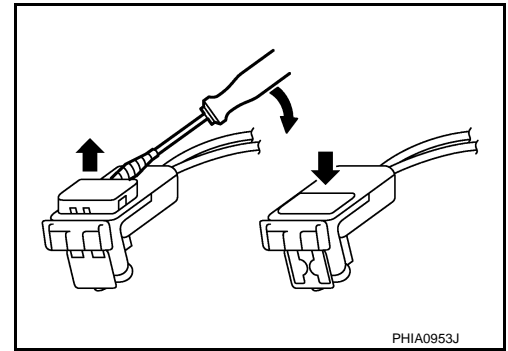

3. Disengage lid (B) using a remover tool (A), pull down passenger air bag module (1) by arrows as shown in the figure.

← : Vehicle front

② Instrument panel assembly

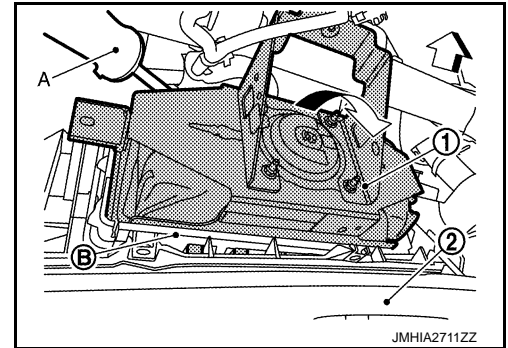

4. Remove passenger air bag module from instrument panel assembly according to numerical order 1→2 indicated by arrows as shown in the figure.

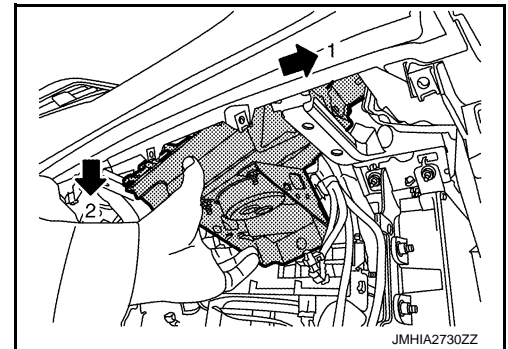

CAUTION:

PASSENGER AIR BAG MODULE

< REMOVAL AND INSTALLATION >

- To prevent accidental explosion, always place the driver air bag module with deploying direction facing upward.

↶ : Deploying direction

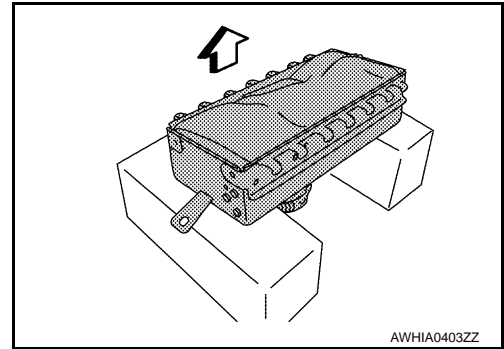

- To prevent damage to the parts, never impact the passenger air bag module.
- Replace the passenger air bag module if it is dropped or sustains an impact.



- To prevent accidental explosion, never insert any foreign objects (screwdriver, etc.) into the passenger air bag module.
- To prevent accidental explosion, never disassemble the passenger air bag module.
- To prevent accidental explosion, never expose the passenger air bag module to temperature of more than 90 °C (194 °F).
- To prevent damage to the parts, never allow oil, grease, detergent, or water to come in contact with the passenger air bag module.

INSTALLATION

Note the following items, and then install in the reverse order of removal.

CAUTION:

- Never reuse mounting bolts after removal, replace with new bolts.
- Never damage the harness while installing.
- After installation is complete, perform self-diagnosis using CONSULT or air bag warning lamp, if the system is normal and "PAST" of "Self Diagnostic Result" is indicated, always perform "ERASE" of "Self Diagnostic Result" using CONSULT. Refer to [SRC-38, "Work Flow"](#).
- After the work is completed, check that no system malfunction is detected by air bag warning lamp in the user mode.

A
B
C
D
E
F
G
SR
I
J
K
L
M
N
O
P

CURTAIN AIR BAG MODULE

< REMOVAL AND INSTALLATION >

CURTAIN AIR BAG MODULE

Exploded View

INFOID:000000011285534

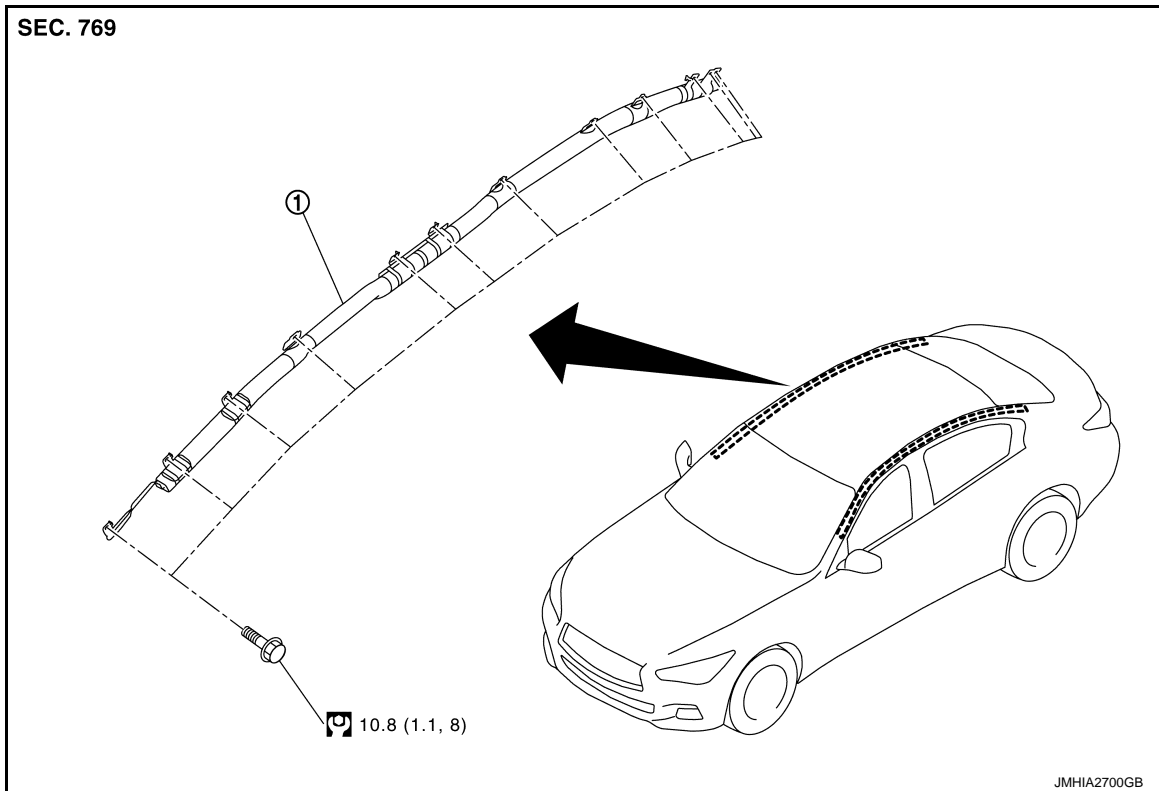

① Curtain air bag module

 : N·m (kg-m, ft-lb)

Removal and Installation

INFOID:000000011285535

WARNING:

Always observe the following items for preventing accidental activation.

- Before servicing, turn ignition switch OFF, disconnect battery negative terminal and wait for 3 minutes or more (discharges electricity held in the additional power supply circuit of the air bag diagnosis sensor unit).
- Always work from the side of curtain air bag module. Never work in front of it.

REMOVAL

1. Remove headlining assembly. Refer to [INT-42. "Removal and Installation"](#).
2. Disconnect curtain air bag module harness connector.

CAUTION:

- For installing/removing the curtain air bag harness connector, insert a thin screwdriver wrapped in tape into notch, lift lock and remove the connector.
- Install the connector with lock raised, and push lock into the connector.
- After installing the connector, check that the lock is pushed securely into it.

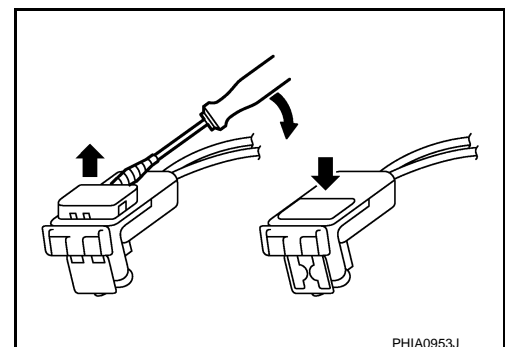

CURTAIN AIR BAG MODULE

< REMOVAL AND INSTALLATION >

3. Remove curtain air bag module mounting bolts, and then remove curtain air bag module.

CAUTION:

- To prevent damage to the parts, never impact the curtain air bag module.
- Replace the curtain air bag module if it is dropped or sustains an impact.



- To prevent accidental explosion, never insert any foreign objects (screwdriver, etc.) into the curtain air bag module.
- To prevent accidental explosion, never disassemble the curtain air bag module.
- To prevent accidental explosion, never expose the curtain air bag module to temperatures of more than 90°C (194°F).
- To prevent damage to the parts, never allow oil, grease, detergent, or water to come in contact with the curtain air bag module.

INSTALLATION

Note the following items, and then install in the reverse order of removal.

CAUTION:

- Check perforation of curtain air bag module to check that curtain air bag module is not twisted.
- Never damage the harness while installing.
- After installation is complete, perform self-diagnosis using CONSULT or air bag warning lamp, if the system is normal and "PAST" of "Self Diagnostic Result" is indicated, always perform "ERASE" of "Self Diagnostic Result" using CONSULT. Refer to [SRC-38, "Work Flow"](#).
- After the work is completed, check that no system malfunction is detected by air bag warning lamp in the user mode.

A
B
C
D
E
F
G
SR
I
J
K
L
M
N
O
P

CRASH ZONE SENSOR

< REMOVAL AND INSTALLATION >

CRASH ZONE SENSOR

Exploded View

INFOID:000000011285536

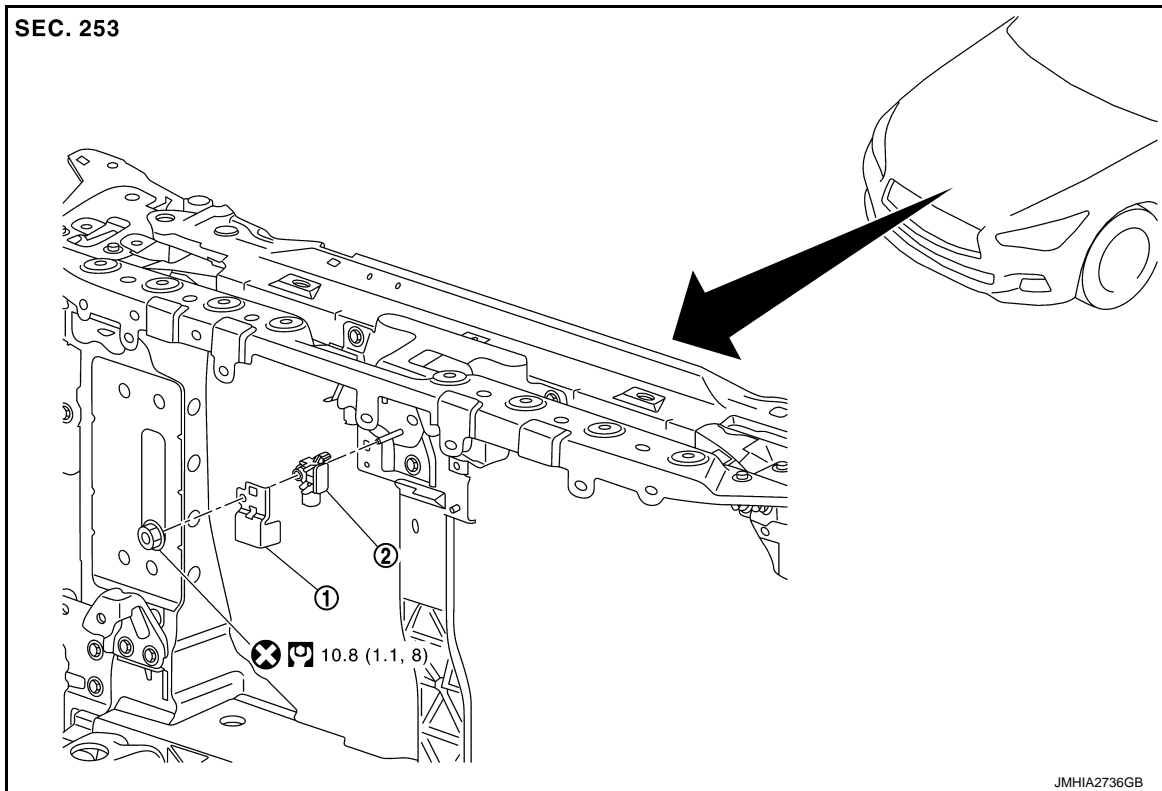

- ① Bracket ② Crash zone sensor

⊗ : Always replace after every disassembly.

🔧 : N·m (kg-m, ft-lb)

Removal and Installation

INFOID:000000011285537

WARNING:

Always observe the following items for preventing accidental activation.

- Before servicing, turn ignition switch OFF, disconnect battery negative terminal and wait for 3 minutes or more (discharges electricity held in the additional power supply circuit of the air bag diagnosis sensor unit).
- Never use air tools or electric tools for servicing (prevents the air bag diagnosis sensor unit from activating unexpectedly due to vibration).

REMOVAL

1. Remove air duct (inlet). Refer to [EM-30. "Removal and Installation"](#).
2. Remove the crash zone sensor mounting nut, and then remove bracket.
3. Disconnect the crash zone sensor harness connector, and then remove crash zone sensor.

CAUTION:

CRASH ZONE SENSOR

< REMOVAL AND INSTALLATION >

- To prevent damage to the parts, never impact the crash zone sensor.
- Replace the crash zone sensor if it is dropped or sustains an impact.



- Replace the crash zone sensor of deployed driver air bag module, deployed passenger air bag module, seat belt pre-tensioner and deployed lap pre-tensioner.

INSTALLATION

Note the following items, and then install in the reverse order of removal.

CAUTION:

- Never reuse mounting nut after removal, replace with new nut.
- Never damage the harness while installing.
- Always install normally aligning to the cutout hole, because performance of the crash zone sensor excessively fluctuates according to the installation position.
- After installation is complete, perform self-diagnosis using CONSULT or air bag warning lamp, if the system is normal and "PAST" of "Self Diagnostic Result" is indicated, always perform "ERASE" of "Self Diagnostic Result" using CONSULT. Refer to [SRC-38, "Work Flow"](#).
- After the work is completed, check that no system malfunction is detected by air bag warning lamp in the user mode.

A
B
C
D
E
F
G
SR
I
J
K
L
M
N
O
P

SATELLITE SENSOR

< REMOVAL AND INSTALLATION >

SATELLITE SENSOR

Exploded View

INFOID:000000011285538

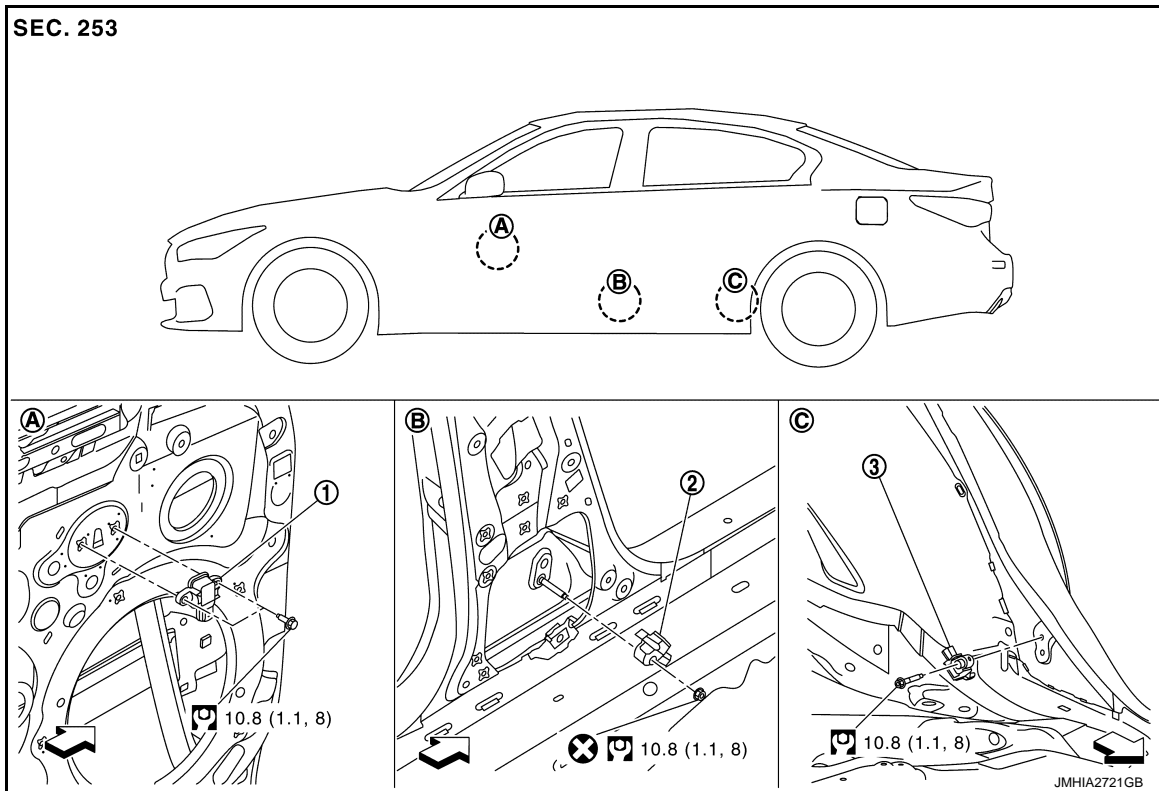

- ① Front door satellite sensor ② B-pillar satellite sensor ③ C-pillar satellite sensor

← : Vehicle front

⊗ : Always replace after every disassembly.

Ⓜ : N·m (kg·m, ft·lb)

Removal and Installation

INFOID:000000011285539

WARNING:

Always observe the following items for preventing accidental activation.

- Before servicing, turn ignition switch OFF, disconnect battery negative terminal and wait for 3 minutes or more (discharges electricity held in the additional power supply circuit of the air bag diagnosis sensor unit).
- Never use air tools or electric tools for servicing (prevents the air bag diagnosis sensor unit from activating unexpectedly due to vibration).

REMOVAL

Front door Satellite Sensor

1. Remove front door finisher. Refer to [INT-13, "FRONT DOOR FINISHER : Removal and Installation"](#).
2. Remove front door satellite sensor mounting bolts.
3. Disconnect front door satellite sensor harness connector, and then remove front door satellite sensor.

CAUTION:

SATELLITE SENSOR

< REMOVAL AND INSTALLATION >

- To prevent damage to the parts, never impact the satellite sensor.
- Replace the satellite sensor if it is dropped or sustains an impact.



- Replace the satellite sensor of deployed side air bag module and deployed curtain air bag module.

B-pillar Satellite Sensor

1. Remove center pillar lower garnish. Refer to [INT-28, "CENTER PILLAR LOWER GARNISH : Removal and Installation"](#).
2. Remove front seat belt pre-tensioner retractor assembly. Refer to [SB-9, "SEAT BELT RETRACTOR : Removal and Installation"](#).
3. Remove B-pillar satellite sensor mounting nut.
4. Pull out B-pillar satellite sensor from the vehicle.
CAUTION:
Never damage the B-pillar satellite sensor harness.
5. Disconnect B-pillar satellite sensor harness connector, and then remove B-pillar satellite sensor.

- To prevent damage to the parts, never impact the satellite sensor.
- Replace the satellite sensor if it is dropped or sustains an impact.



- Replace the satellite sensor of deployed side air bag module and deployed curtain air bag module.

C-pillar Satellite Sensor

1. Remove rear seat cushion. Refer to [SE-97, "SEAT CUSHION : Removal and Installation"](#) (Bench seat models) or [SE-106, "SEAT CUSHION : Removal and Installation"](#) (6:4 separate seat models).
2. Rear wheel house garnish. Refer to [INT-30, "REAR WHEEL HOUSE GARNISH : Removal and Installation"](#).
3. Remove C-pillar satellite sensor mounting bolt.
4. Disconnect C-pillar satellite sensor harness connector and then remove C-pillar satellite sensor.
CAUTION:

A
B
C
D
E
F
G
SR
I
J
K
L
M
N
O
P

SATELLITE SENSOR

< REMOVAL AND INSTALLATION >

- To prevent damage to the parts, never impact the satellite sensor.
- Replace the satellite sensor if it is dropped or sustains an impact.



- Replace the satellite sensor of deployed side air bag module, deployed curtain air bag module.

INSTALLATION

Note the following items, and then install in the reverse order of removal.

CAUTION:

- Never reuse mounting nut after removal, replace with the new nut.
- Never damage the harness while installing.
- Always install normally aligning to the cutout hole, because performance of the satellite sensor excessively fluctuates according to the installation position.
- After installation is complete, perform self-diagnosis using CONSULT or air bag warning lamp, if the system is normal and "PAST" of "Self Diagnostic Result" is indicated, always perform "ERASE" of "Self Diagnostic Result" using CONSULT. Refer to [SRC-38. "Work Flow"](#).
- After the work is completed, check that no system malfunction is detected by air bag warning lamp in the user mode.

SEAT BELT PRE-TENSIONER

< REMOVAL AND INSTALLATION >

SEAT BELT PRE-TENSIONER

Exploded View

INFOID:000000011285540

For exploded view of seat belt pre-tensioner. Refer to [SB-8. "Exploded View"](#).

Removal and Installation

INFOID:000000011285541

For removal and installation procedures. Refer to [SB-9. "SEAT BELT RETRACTOR : Removal and Installation"](#).

- A
- B
- C
- D
- E
- F
- G
- SR
- I
- J
- K
- L
- M
- N
- O
- P



LAP PRE-TENSIONER

< REMOVAL AND INSTALLATION >

LAP PRE-TENSIONER

Exploded View

INFOID:00000001128542

Refer to [SB-8. "Exploded View"](#).

Removal and Installation

INFOID:00000001128543

For removal and installation procedures, refer to [SB-14. "SEAT BELT RETRACTOR : Removal and Installation"](#).

DIAGNOSIS SENSOR UNIT

< REMOVAL AND INSTALLATION >

DIAGNOSIS SENSOR UNIT

Exploded View

INFOID:000000011285544

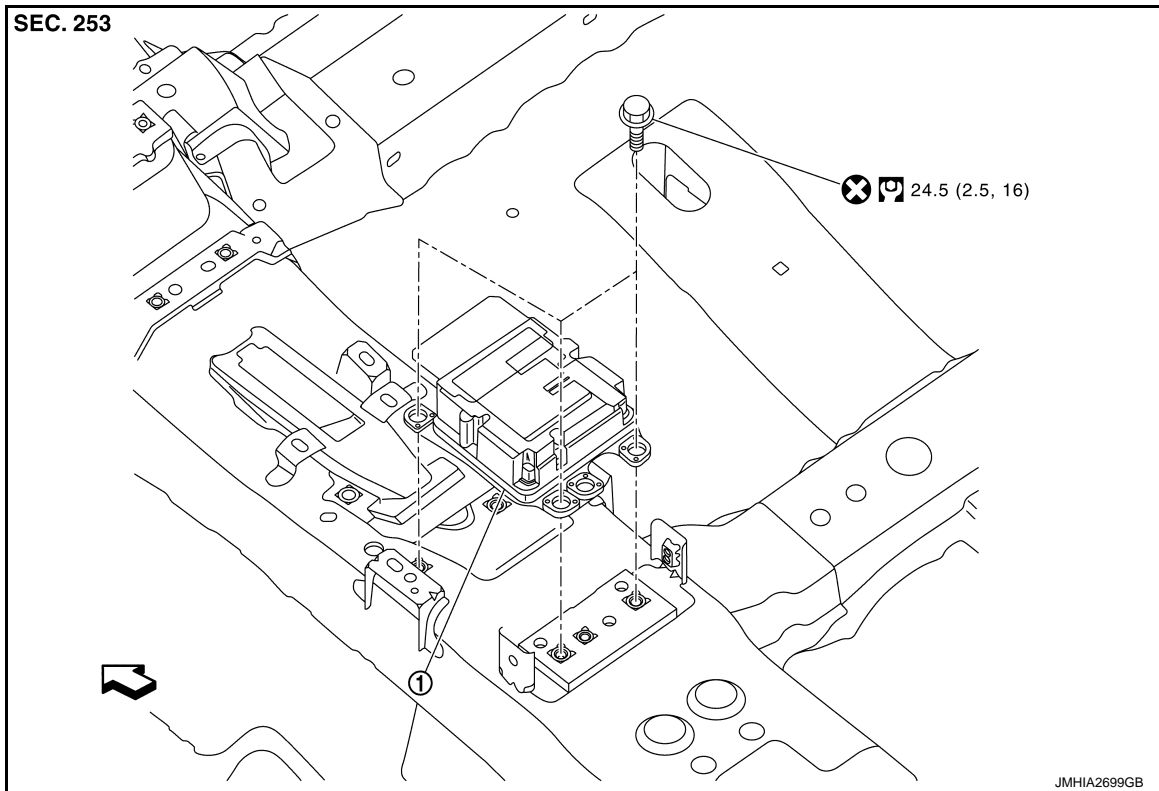

① Air bag diagnosis sensor unit

⊗ : Always replace after every disassembly.

⊗ : N·m (kg·m, ft·lb)

← : Vehicle front

Removal and Installation

INFOID:000000011285545

WARNING:

Always observe the following items for preventing accidental activation.

- Before servicing, turn ignition switch OFF, disconnect battery negative terminal and wait for 3 minutes or more (discharges electricity held in the additional power supply circuit of the air bag diagnosis sensor unit).
- Before disconnecting the air bag sensor unit harness connector, be sure to disconnect each harness connector of the air bag modules, seat belt pre-tensioners and lap pre-tensioner to prevent air bag deployment by static electricity and seat belt pre-tensioner operation.
- Never use air tools or electric tools for servicing (prevents the air bag diagnosis sensor unit from activating unexpectedly due to vibration).
- When replacing the air bag diagnosis sensor unit, always check with the parts department for the latest parts information. Installing an incorrect air bag diagnosis sensor unit may or may not cause the air bag warning lamp to illuminate and may cause incorrect deployment of the supplemental air bags and seat belt pre-tensioners in a collision resulting in serious personal injury or death.

REMOVAL

1. Always check the air bag diagnosis sensor unit discriminated number (identification number) using CONSULT.
2. Disconnect the connector of all air bag modules, seat belt pre-tensioners and lap pre-tensioner.
3. Remove center console assembly. Refer to [IP-24, "Removal and Installation"](#).

A

B

C

D

E

F

G

SR

I

J

K

L

M

N

O

P

DIAGNOSIS SENSOR UNIT

< REMOVAL AND INSTALLATION >

4. Remove rear floor duct 2. Refer to [VTL-13, "REAR FLOOR DUCT 2 : Removal and Installation"](#).
5. Disconnect air bag diagnosis sensor unit harness connectors.
6. Remove air bag diagnosis sensor unit mounting bolts, and then remove air bag diagnosis sensor unit.

CAUTION:

- To prevent damage to the air bag diagnosis sensor unit, never impact it
- Replace the diagnosis sensor unit if it is dropped or sustains an impact.



- Replace the diagnosis sensor unit of deployed driver air bag module, deployed passenger air bag module, deployed side air bag module, deployed curtain air bag module, deployed seat belt pre-tensioner or deployed lap pre-tensioner.

INSTALLATION

Note the following items, and then install in the reverse order of removal.

CAUTION:

- Never reuse mounting bolts after removal, replace with new bolts.
- Never damage the harness while installing.
- After installation is complete, perform self-diagnosis using CONSULT or air bag warning lamp, if the system is normal and "PAST" of "Self Diagnostic Result" is indicated, always perform "ERASE" of "Self Diagnostic Result" using CONSULT. Refer to [SRC-38, "Work Flow"](#).
- After the work is completed, check that no system malfunction is detected by air bag warning lamp in the user mode.
- After replacing the air bag diagnosis sensor unit, confirm using CONSULT that the ECU discriminated number (identification number) of the new replacement air bag sensor unit matches the ECU discriminated number (identification number) of the replaced (old) air bag diagnosis sensor unit.

NOTE:

If the ECU discriminated number of the new replacement air bag diagnosis sensor unit differs from the ECU discriminated number of the replaced air bag diagnosis sensor unit, reconfirm the parts information and verify that the correct air bag diagnosis sensor unit was installed.

OCCUPANT CLASSIFICATION SYSTEM CONTROL UNIT

< REMOVAL AND INSTALLATION >

OCCUPANT CLASSIFICATION SYSTEM CONTROL UNIT

Exploded View

INFOID:000000011285546

Refer to [SE-78, "Exploded View"](#).

Removal and Installation

INFOID:000000011285547

REMOVAL

1. Remove passenger seat assembly. Refer to [SE-79, "Removal and Installation"](#).
2. Remove fixing screws, and then remove occupant detection system control unit from seat cushion flame.
3. Disconnect harness connector from occupant detection system control unit.

INSTALLATION

Install in the reverse order of removal.

A
B
C
D
E
F
G
SR
I
J
K
L
M
N
O
P

